

**SILVELOX**  
OPEN YOUR SPACE

MATY  
FLAMMA 60

# MATY

Maty è la porta d'ingresso blindata Silvelox in classe 3 antieffrazione studiata per le principali esigenze in caso di ristrutturazioni e sostituzioni di porte d'ingresso capo scala.

Non necessita di installare il controtelaio perché progettata con un telaio tubolare verniciato, facile e veloce da installare. La dotazione di un sistema di cerniere a scomparsa creano un effetto complanare nel lato interno porta per un risultato elegante e funzionale.

Disponibile in una vasta gamma di estetiche e finiture a collezione.

Maty is the Silvelox class 3 burglar-proof armoured entrance door designed for Internal Security necessities and apartments.

It is designed with a painted tubular frame, which is easy, and quick to install without subframes. A concealed hinges system creates either a coplanar effect on the inside of the door for an elegant and functional result or a seamless positioning flush with surrounding walls or claddings.

Maty is offered in a wide range of aesthetics options and finishes.

MATY  
Family Lisci  
Modello Zenith  
HDF laccato Ral 1015

MATY  
Family Lisci  
Model Zenith  
Ral 1015

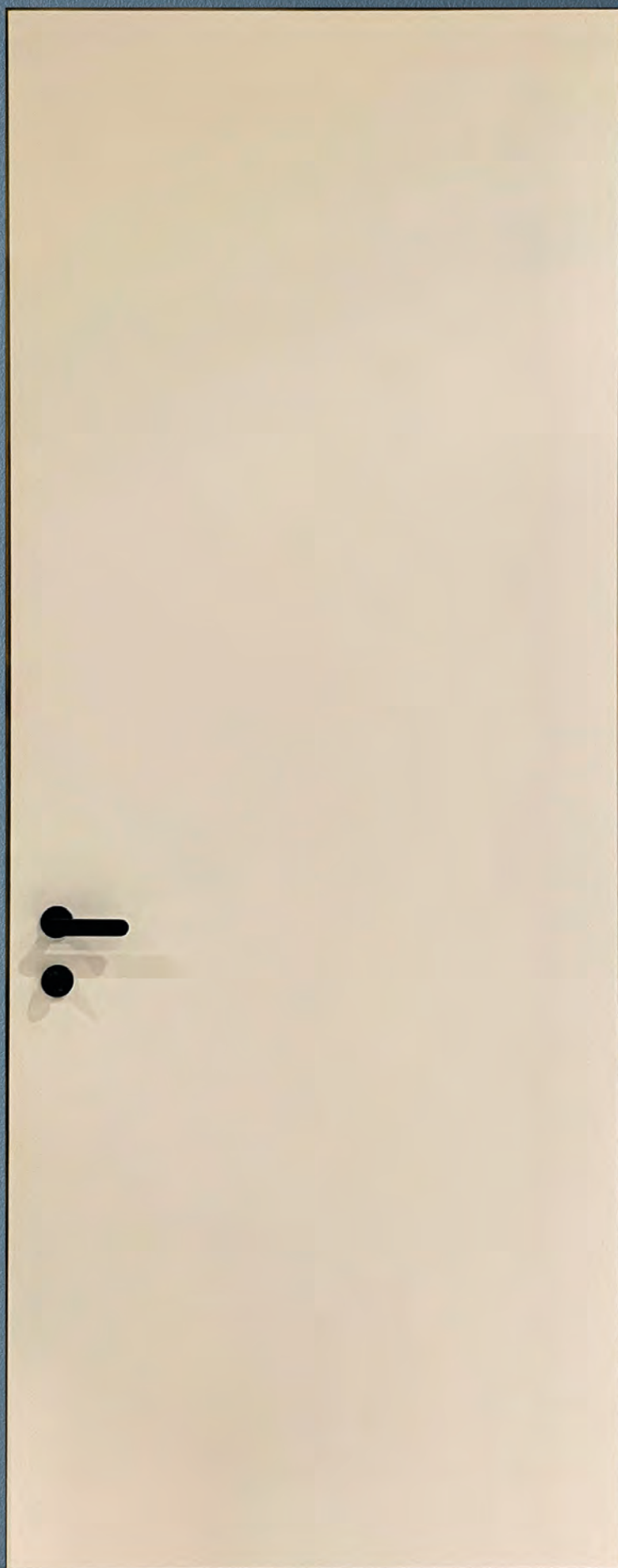

# LE UNICITÀ DI UNIQUE POINTS OF DISTINCTION OF MATY

**CLASSE 3 ANTIEFFRAZIONE**  
**CERNIERA A SCOMPARSA REGOLABILE**  
**COMPLANARIETÀ INTERNA**  
**SENZA CONTROTELAIO**  
**VERNICIATURA COVER SCOCCA**  
**E TELAIO A SCELTA**

**SECURITY CLASS 3**  
**ADJUSTABLE CONCEALED HINGES**  
**INTERNAL COMPLANARITY**  
**NO COUNTERFRAME**  
**COVER AND FRAME**  
**COLORS AT CHOICE**



**ISOLAMENTO TERMICO**  
**CON INDICE DI TRASMITTANZA**  
**TERMICA FINO A 1,3 W/M<sup>2</sup>K CON KIT**  
Prestazioni standard 1,6 W/m<sup>2</sup>K

**THERMAL INSULATION**  
**UP TO U=1,3 W/M<sup>2</sup>K WITH KIT**  
Standard performance 1,6 W/m<sup>2</sup>K



**CERTIFICATA ISOLAMENTO**  
**ACUSTICO 40 DB CON KIT**  
Prestazioni standard 36 DB

**ACOUSTIC INSULATION**  
**CERTIFICATE 40 DB WITH KIT**  
Standard performance 36 DB



**ACQUA CLASSE 6B**  
**ARIA CLASSE 4**  
**VENTO CLASSE C2**

**WATER CLASS 6B**  
**AIR CLASS 4**  
**WIND CLASS C2**

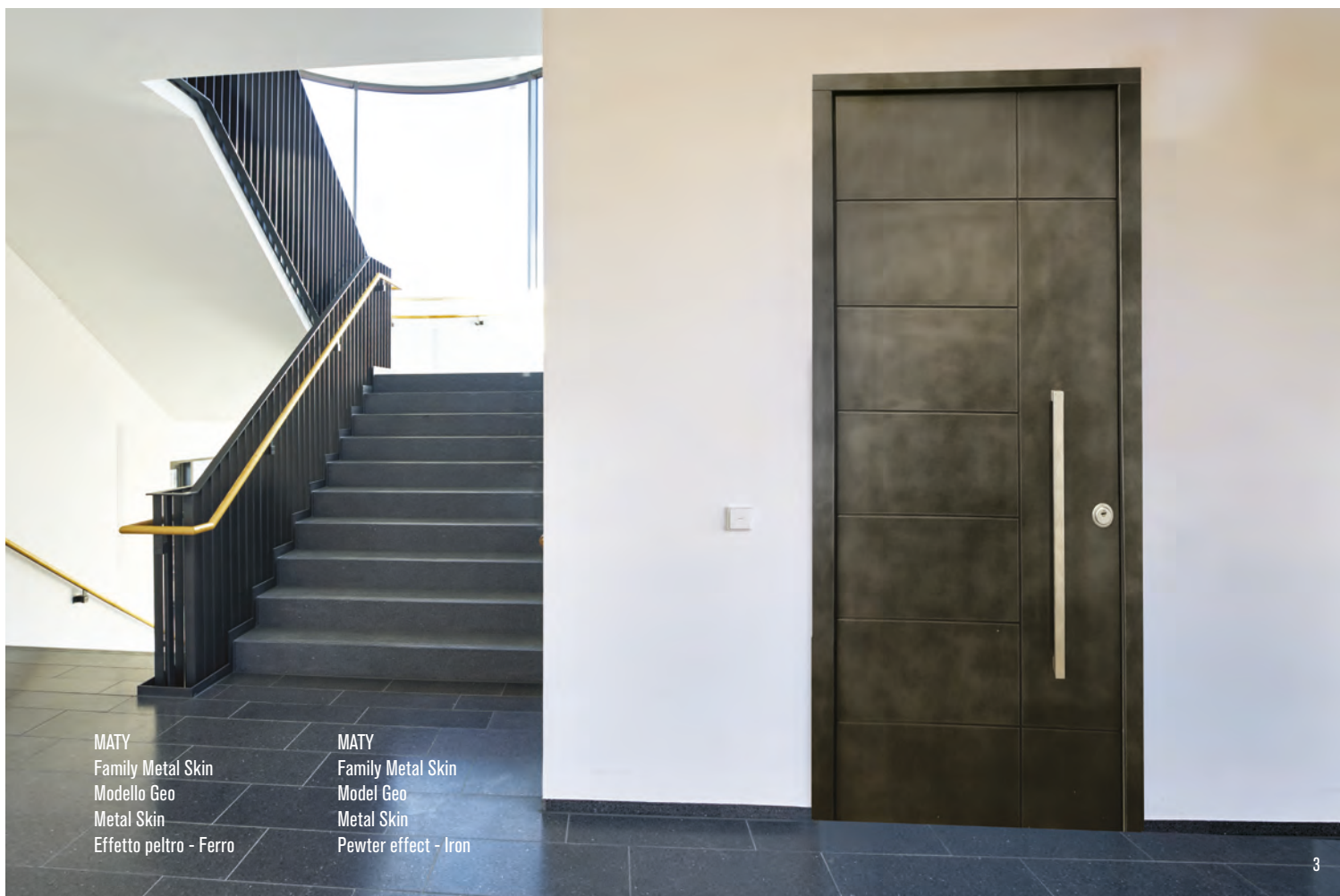

MATY  
Family Metal Skin  
Modello Geo  
Metal Skin  
Effetto peltro - Ferro

MATY  
Family Metal Skin  
Model Geo  
Metal Skin  
Pewter effect - Iron

# LE UNICITÀ DI UNIQUE POINTS OF DISTINCTION OF MATY

## PORTA COMPLANARE FILO MURO INTERNO

La porta si libera così di cornici e stipiti ottenendo una totale coplanarietà con il supporto per un risultato estetico all'insegna dell'eleganza e della pulizia estetica.

Una proposta dal look contemporaneo e dal design essenziale rivolta a coloro che ricercano sicurezza ed elevate prestazioni di isolamento termico ed acustico senza dover rinunciare ad un prodotto esclusivo e di qualità.

## INTERNAL COPLANARITY

The door is thus free of frames and jambs obtaining a total coplanarity with the support for an aesthetic result characterized by elegance and formal cleanliness. A proposal with a contemporary look and an essential design aimed at those who seek safety and high performance of thermal and acoustic insulation without having to give up an exclusive and quality product.

MATY  
Family Lisci  
Modello Zenith  
HDF laccato Ral 1015

MATY  
Family Lisci  
Model Zenith  
Ral 1015



**SOLUZIONE CON COPRIFILI  
INTERNI COMPLANARI  
VERSION EQUIPPED WITH INTERNAL  
COPLANAR TRIMS**

**SOLUZIONE  
CON FILOMURO  
INTERNAL WALL FLUSH  
INSTALLATION**

Verniciatura Cover del telaio e carenatura  
fermapannello esterno disponibili nelle colorazioni  
RAL a richiesta Texturizzate. Standard costruttivo  
cover del telaio RAL 9010 di serie e carenatura  
in acciaio inox satinato AISI 304

Door metal perimetric edges available in all RAL  
textured colors.

Standard door covers kit made in Stainless steel AISI  
304 and standard metal frame color RAL 9010.

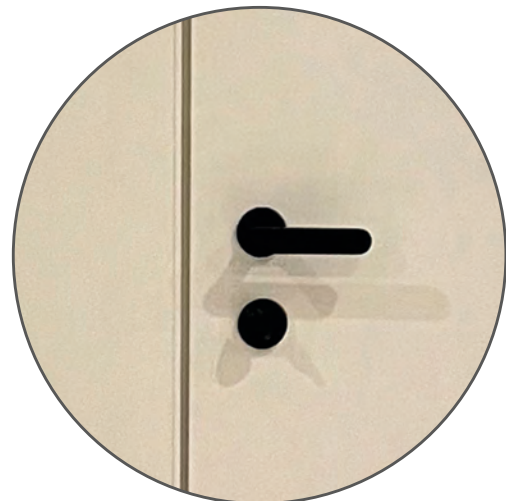



**CERNIERA A SCOMPARSA REGOLABILE  
E APERTURA A 90 GRADI  
CON COPRICERNIERA  
ADJUSTABLE CONCEALED HINGES  
WITH COLOURED COVERS  
(90 DEGREES OPENING)**



**SOLUZIONE  
KIT IMBOTTE  
PERIMETRIC  
JAMBS AVAILABLE**

**CARENATURA FERMAPANNELLO ESTERNO IN ACCIAIO INOX SATINATO  
SATIN-FINISHED STAINLESS STEEL DOOR PERIMETRIC EDGES**



**SISTEMA  
CILINDRI  
DI SICUREZZA**

**SAFETY  
CYLINDERS  
SYSTEM**

**CILINDRO:**

- 5 chiavi padronali
- 2 chiavi cantieri
- Carta di sicurezza

**CYLINDER:**

- 5 master keys
- 2 building site keys
- Security card

MATY  
Family Linee  
Modello Geo  
Okoumé  
tinta Douglas

MATY  
Family Linee  
Model Geo  
Okoumé  
laquered Douglas



# FLAMMA 60

La soluzione di chiusura ideale per ambienti a rischio incendi o per compartimentare locali come ingressi di negozi, magazzini, ristoranti, uffici, ospedali, case di cura, ambienti pubblici.

The ideal closure solution for areas at risk of fire such as the entrances to shops, warehouses, restaurants, offices, hospitals, nursing homes, public spaces.



FLAMMA 60  
Family Lisci  
Modello Zenith  
Okoumé  
Ral 3003

FLAMMA 60  
Family Lisci  
Model Zenith  
Okoumé  
Ral 3003



# SICUREZZA SECURITY

# 3 classe class

Flamma 60 garantisce gli standard di sicurezza in Classe 3 alla performance tagliafuoco omologata REI 60 nel rispetto della normativa EN 1634

Flamma 60 guarantees Class 3 safety standards for REI 60 approved fire-resistance performance in compliance with the EN 1634 standard

## TAGLIAFUOCO FIRE-RESISTANCE

# REI 60

### SISTEMA DI AUTOCHIUSURA SELF-CLOSING SYSTEM

Tutte le porte tagliafuoco, possono avere come accessorio un sistema di autochiusura, chiudiporta idraulico aereo a vista nelle finiture: testa di moro, bianco argento e gold o incassato (previa autorizzazione ufficio tecnico) Foto 1

The doors, can have as an accessory a self-closing system with visible aerial hydraulic door closer in the finishes: dark brown, silver white and gold or recessed (subject to authorization technical office)



**ISOLAMENTO TERMICO  
CON INDICE DI TRASMITTANZA  
TERMICA FINO A 1,8 W/M<sup>2</sup>K CON KIT**

**THERMAL INSULATION  
UP TO U=1,8 W/M<sup>2</sup>K WITH KIT**



**CERTIFICATA ISOLAMENTO  
ACUSTICO 41 DB CON KIT**

**ACOUSTIC INSULATION  
CERTIFICATE 41 DB WITH KIT**



**ACQUA CLASSE 6B  
ARIA CLASSE 4**

**WATER CLASS 6B  
AIR CLASS 4**



Foto 1  
Accessorio sistema di autochiusura  
Accessory system of self-closing

## FAMILY DESIGN

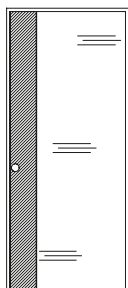

MODELLO  
FLAT  
LINE

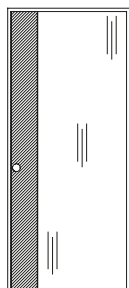

MODELLO  
FLAT  
ZENITH

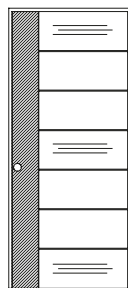

MODELLO  
LAYER  
LINE

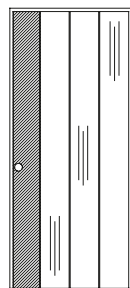

MODELLO  
LAYER  
ZENITH

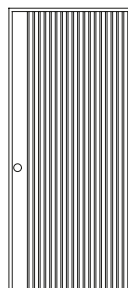

MODELLO  
MILLERIGHE\*

Pannello in fibra di legno alta densità **HDF** o pannello multistrato con superficie in essenza o pannello multistrato marino nobilitato in essenza.  
Spessore 15 mm.

**HDF** High density fiber wood panel or hardwood plywood panel or wood veneer marine plywood panel.  
Thickness 15 mm.

\* Disponibile solo nelle finiture Okoumé, HDF e rovere impregnato/naturale.

\* Available only in the finishes Okoumé, HDF and oak impregnated/natural.

## FAMILY LISCI

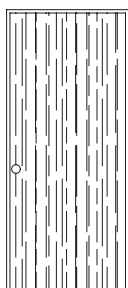

MODELLO  
ZENITH

Pannello in fibra di legno alta densità **HDF**.  
Spessore 6/10 mm.  
Completo di angolari fermapannello se previsto per lato interno porta.

**HDF** High density fiber wood panel.  
Thickness 6/10 mm.  
Complete with panel corner holder if provided for the inside of the door.

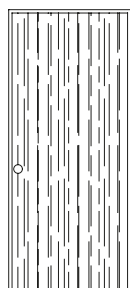

MODELLO  
ZENITH

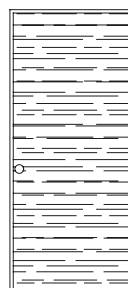

MODELLO  
LINE

Pannello multistrato con superficie in essenza.  
Spessore 6/10 mm con pannello bordato.

Hardwood plywood  
Thickness 6/10 mm with edged panel

Pannello multistrato marino nobilitato in essenza.  
Spessore 6/10 mm con pannello bordato.

Wood veneer marine plywood  
Thickness 6/10 mm with edged panel

## FAMILY LINEE

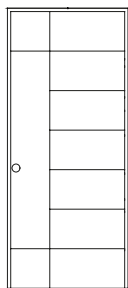

MODELLO  
GEO

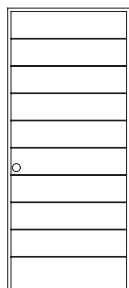

MODELLO  
FOR

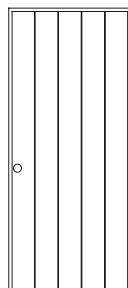

MODELLO  
VIP

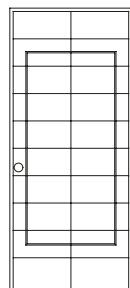

MODELLO  
ZEN

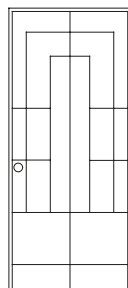

MODELLO  
ARA

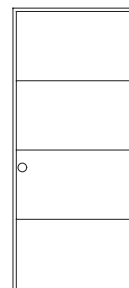

MODELLO  
TRIO

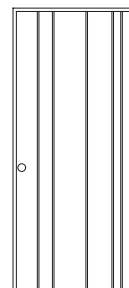

MODELLO  
NEWMAN

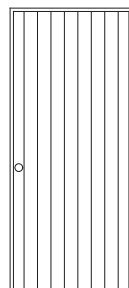

MODELLO  
DOC

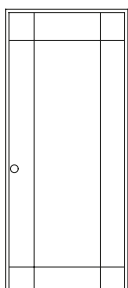

MODELLO  
QUADRA

Pannello in fibra di legno alta densità **HDF** o pannello multistrato con superficie in essenza o pannello multistrato marino nobilitato in essenza.  
Spessore 15 mm. Completo di angolari fermapannello se previsto per lato interno porta.

**HDF** High density fiber wood panel or hardwood plywood panel or wood veneer marine plywood panel.  
Thickness 15 mm. Complete with panel corner holder if provided for the inside of the door.

# FAMILY MONOFRESATA

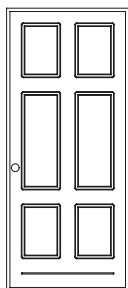

MODELLO  
P 100

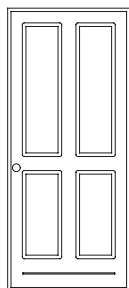

MODELLO  
P 101

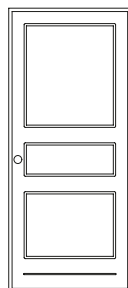

MODELLO  
P 104

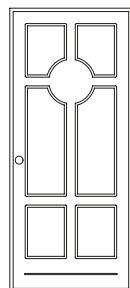

MODELLO  
P 106

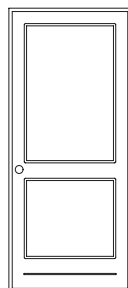

MODELLO  
P 115

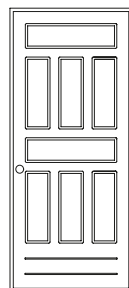

MODELLO  
P 117

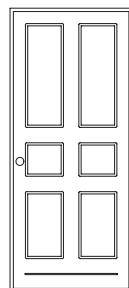

MODELLO  
P 118

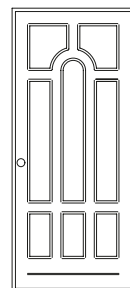

MODELLO  
P 120

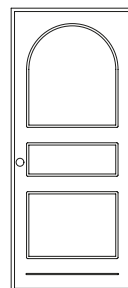

MODELLO  
P 121

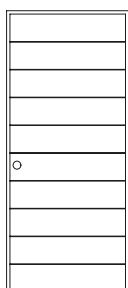

MODELLO  
P 122

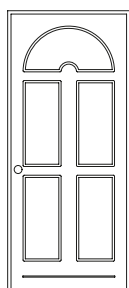

MODELLO  
P 125

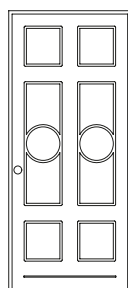

MODELLO  
P 131

Pannello in fibra di legno alta densità **HDF** o pannello multistrato con superficie in essenza.  
Spessore 14 mm con pannello bordato.

**HDF** High density fiber wood panel or hardwood plywood panel.  
Thickness 14 mm with edged panel

# ESSENZE

**PANNELLO IN MULTISTRATO CON SUPERFICIE IN ESSENZA / HARDWOOD PLYWOOD**  
**PANNELLO IN MULTISTRATO MARINO NOBILITATO IN ESSENZA / WOOD VENEER MARINE PLYWOOD**  
**NATURALI E DA LACCARE O IMPREGNARE / NATURAL AND TO BE LACQUERED OR IMPREGNATED**  
adatto per esterni / Suitable for outdoors



Okoumé / Okoumé



Larice / Larch



Larice Spazzolato / Brushed larch



Rovere / Oak



Rovere Spazzolato / Rused Oak

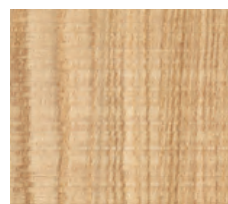

Rovere Segato / Sawn Oak

## DISPONIBILI NELLE FINITURE IMPREGNATE / AVAILABLE IN IMPREGNATED FINISHING

Adatto per esterni / Suitable for outdoors



Tinta Miele / Honey colour



Tinta Rovere / Oak colour

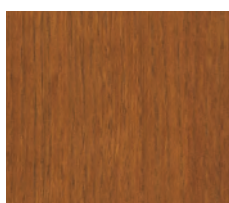

Tinta Douglas / Douglas colour



Tinta Ciliegio / Cherry colour

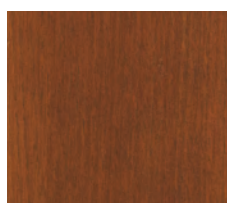

Tinta Mogano / Mahogany colour

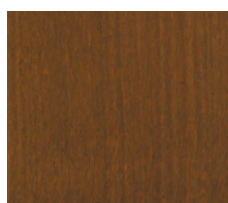

Tinta Noce / Walnut Colour

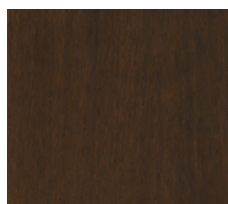

Tinta Noce Scuro / Dark walnut colour



Tinta Verde / Green colour



Laccature NCS / NCS Lacquers



Tutti i colori RAL / All RAL colors

Esempio su base Rovere ma disponibile su tutte le essenze  
Example on Oak base but available on all types of wood

## ALTRE ESSENZE

### NATURALI / NATURALS

Adatto per esterni / Suitable for outdoors

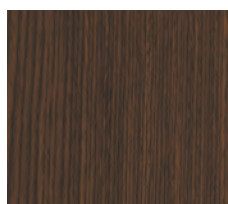

Wengè / Wengè



Noce Canaletto / Canaletto Walnut



Noce Nazionale / Walnut medium



Teak / Teak



Larice cotto / Aged Larch



Abete nordico / Northern Spruce

## TRANCIATI / PARTICLE BOARDS



Rovere Miele / Honey oak



Rovere / Oak



Mogano Naturale / Natural mahogany



Mogano Medio / Medium mahogany



Tanganica Chiaro / Light Tanganica

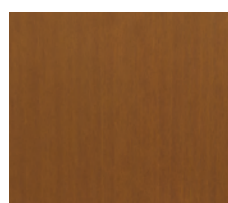

Taganita Medio / X Medium Tanganica

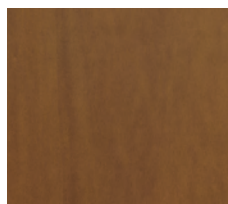

Tanganica Medio Scuro / Dark medium Tanganica

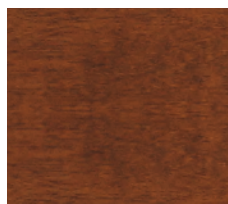

Tanganica Scuro / Dark Tanganica

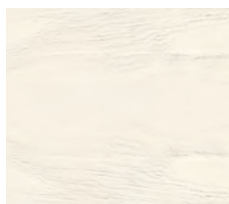

Frassino bianco / White ash



Noce Nazionale medio / Walnut natural medium



Ciliegio / Cherry

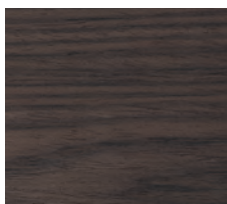

Sil 18.11

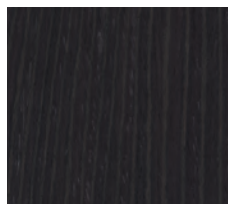

Sil 18.24

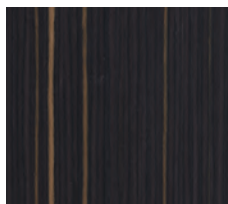

SilEbony



SilGabon

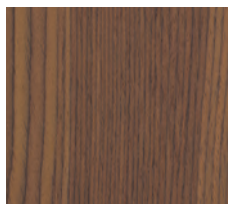

SilMoka

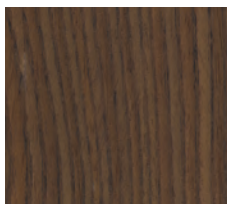

SilTermo

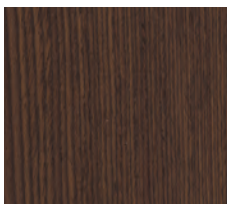

Silwenge

## MELAMINICI / MELAMINIC

Solo per ambienti interni su entrambi i lati / For interiors only, on both door sides



Bianco B011 / White B011

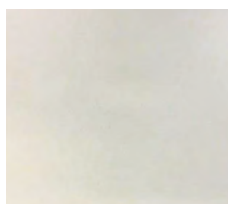

Avorio 1013 / Ivory 1013



Palissandro bianco / White Rosewood



Palissandro lk55 / Rosewood LK55

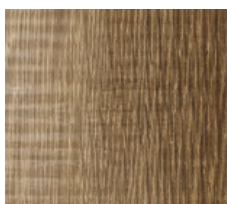

Tranche LM09 / Tranche LM09

## HDF

Solo per ambienti interni su entrambi i lati / For interiors only, on both door sides



BASIC RAL 9003 Bianco / White



Tutti i colori RAL / All RAL colors

## METAL SKIN

### EFFETTO PATINATO / PATINATE EFFECT

Adatto per esterni / Suitable for outdoors

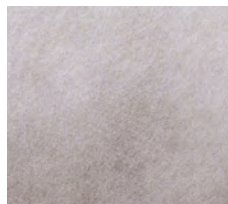

Acciaio / Steel

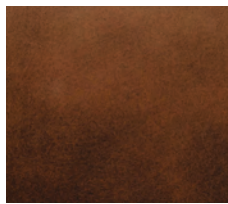

Bronzo / Bronze

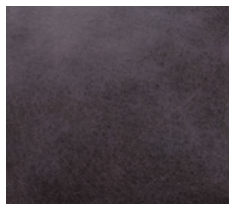

Ferro / Iron



Oro Rosa / Pink Gold



Ottone / Brass

Trattasi di verniciatura manuale disomogenea che rappresenta una caratteristica di unicità artigianale del prodotto. This is a manual painting that represents a characteristic of the craft uniqueness of the product

## METAL SKIN

### EFFETTO PATINATO / PATINATE EFFECT

Adatto per esterni / Suitable for outdoors

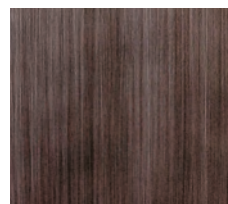

Acciaio / Steel

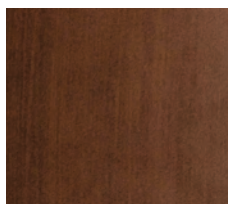

Bronzo / Bronze



Ferro / Iron

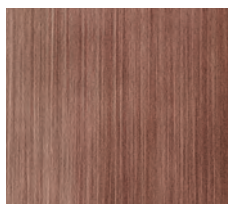

Oro Rosa / Pink Gold



Ottone / Brass

---

## MANIGLIERIA BASE / STANDARD HANDLES

### MANIGLIA LUCE / HANDLE LUCE



Cromo satinato  
Satin chrome



Bronzo satinato  
Satin bronze



Antracite  
Anthracite

### MANIGLIA LUCE 2 / HANDLE LUCE 2



Cromo satinato  
Satin chrome



Bronzo satinato  
Satin bronze



Antracite  
Anthracite

---

## MANIGLIERIA SUPERIOR / SUPERIOR HANDLES

### MANIGLIA CHOP / HANDLE CHOP



Cromo satinato  
Satin chrome



Bronzo satinato  
Satin bronze



Antracite  
Anthracite

### MANIGLIA IKI / HANDLE IKI



Cromo satinato  
Satin chrome



Antracite  
Anthracite

### MANIGLIA PROJECT / HANDLE PROJECT



Ottone Lucido  
Polished Brass

---

## MANIGLIERIA TOP / TOP HANDLES

### MANIGLIA BOOLE / HANDLE BOOLE



Cromo satinato  
Satin chrome



Bronzo satinato  
Satin bronze



Antracite  
Anthracite

### MANIGLIA INFINITO / HANDLE INFINITO



Cromo satinato  
Satin chrome



Bronzo satinato  
Satin bronze



Antracite  
Anthracite

### MANIGLIA DUE / HANDLE DUE



Cromo satinato  
Satin chrome



Bronzo satinato  
Satin bronze



Antracite  
Anthracite

---

## POMOLO GIREVOLE / SWIVEL KNOB

### POMOLO PROJECT ZANCATA 02 / KNOB PROJECT ZANCATA 02



Cromo satinato  
Satin chrome



Bronzo satinato  
Satin bronze



Antracite  
Anthracite

### POMOLO OVUM / KNOB OVUM



Cromo satinato  
Satin chrome



Bronzo satinato  
Satin bronze



Antracite  
Anthracite



Ottone Lucido  
Polished Brass

## POMOLO FISSO / FIXED KNOB

### POMOLO EASY / KNOB EASY



Cromo satinato  
Satin chrome

Disponibile anche nella finitura  
Bronzo satinato, Antracite o Ottone lucido  
Also available in  
Satin Bronze, Anthracite finish or Polished Brass

### POMOLO QUADRO / KNOB QUADRO



Cromo satinato  
Satin chrome

Disponibile anche nella finitura  
Bronzo satinato o Antracite  
Also available in  
Satin Bronze or Anthracite finish

## MANIGLIONI / PULL BARS



**KD**  
Acciaio inox  
Stainless steel



**QUADRO**  
Acciaio inox  
Stainless steel



**CORNER**  
Grigio, Bronzo, Silver  
Grey, Bronze, Silver

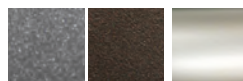

**LOPP**  
Grigio, Bronzo, Silver  
Grey, Bronze, Silver



## TECNOLOGIA SOLO PER MATY DOOR AUTOMATION ONLY FOR MATY

L'arricchimento della base meccanica delle serrature con componenti elettronici di ultima generazione permette di rendere intelligente, e soprattutto più pratico e sicuro, l'accesso all'abitazione.

A seconda delle esigenze, si può scegliere tra un'apertura dall'esterno con lettore transponder (TAG) o una tastiera a codice numerico retroilluminata, per una visione ottimale anche notturna.

Letture transponder (TAG): con questo sistema elettronico la serratura si apre semplicemente avvicinando alla mostrina esterna la chiave elettronica.

Tastiera a codice numerico: il codice numerico digitato (fino ad un massimo di 8 cifre) viene elaborato dal processore della scheda elettronica e, se riconosciuto valido, genera l'apertura della porta.

Altri accessori complementari sono:

- Lettore di impronte
- Dispositivo di apertura da apparecchio telefonico.

The mechanical locks with electronic control allow intelligent and safety operation. According to the specific needs, you can choose an external opening with transponder reader (TAG) or a backlit numeric pad for an optimum sight, also at night.

Transponder reader (TAG): with this electronic system the lock opens simply bringing the electronic key close to the external plate.

Number pad: the numerical code (for a maximum of 8 figures) is controlled electronically by the processor.

Other additional accessories are:

- Fingerprints reader
- Opening by phone.



Serratura motorizzata X1R SMART solo per MATY  
Compatibile con pannelli interni e esterni da almeno 10 mm di spessore

Motorized lock X1R SMART only for MATY  
Internal and external panels thickness at least 10 mm

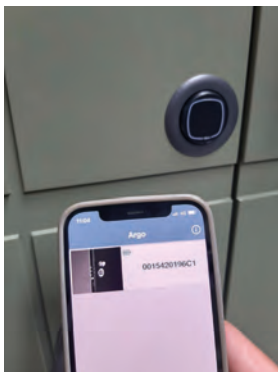

Letture smartphone  
Smartphone reader



Letture Card  
Card reader

# MATY

## CARATTERISTICHE TECNICHE TECHNICAL CHARACTERISTICS

### CHIUSURE DI SICUREZZA

- N° 1 deviatore doppio laterale superiore
- N° 1 deviatore doppio laterale inferiore
- N° 3 rostri fissi

### CARATTERISTICHE TECNICHE

- SCocca in doppia lamiera elettrozincata spessore 12/10 con due rinforzi ad omega verticali spessore 12/10, tutto interamente puntato e saldato. Viene inserita una piastrina di protezione serratura 30/10 in lamiera antitrapano, coibentata con polistirene.
- TELAIO TUBOLARE da 20/10 di spessore, verniciato a polveri termoindurenti nella tinta simil Ral 7016 (grigio antracite).
- CERNIERE a scomparsa regolabili, applicazione della terza cerniera su porte con H > 2200
- DIMENSIONI MASSIME 1000 mm X 2400 mm
- PESO anta + telaio = 100 Kg ca.

### DOTAZIONI DI SERIE

- Carenatura fermapannello esterno in acciaio inox AISI 304 satinato
- Soglia mobile con lama para aria a ghigliottina autolivellante per chiusura a pavimento
- Defender antitubo con trattamento PVD
- Registro scrocco cromato regolabile montato sul telaio
- Guarnizione ad alte prestazioni sul telaio
- Guarnizione ad alte prestazioni sull'anta
- Serratura a cilindro europeo
- Cilindro Top chiave/codolo, 5 chiavi padronali, 1 chiave cantiere e Card di proprietà per duplicazione protetta, Card di sicurezza (con numero seriale del cilindro)
- Sacchetto accessori con tutto il necessario per il montaggio

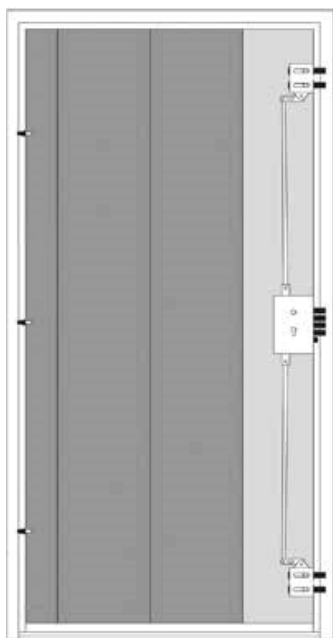

### MULTIPOINT SECURITY LOCKS

- No. 1 top side double diverter
- No. 1 bottom side double diverter
- No. 3 fixed rostrums

### TECHNICAL CHARACTERISTICS

- CHASSIS in double electro-galvanised sheet 12/10 thick with two vertical omega reinforcements 12/10 thick, all fully pointed and welded. A 30/10 drill-proof sheet metal lock protection plate, insulated with polystyrene, is inserted.
- 20/10 thick TUBULAR FRAME, powder-coated thermosetting in a Ral 7016-like colour (anthracite grey).
- Adjustable concealed hinges, application of third hinge on doors with H > 2200
- MAXIMUM DIMENSIONS 1000 mm X 2400 mm
- Sash weight + frame = 100 kg approx.

### STANDARD SETTINGS

- AISI 304 satin-finished stainless steel outer panel fairing
- Movable air curtain with self-levelling guillotine blade for floor closure
- PVD-treated defender
- Frame-mounted adjustable chrome-plated latch register
- High-performance gasket on the frame
- High-performance gasket on sash
- European cylinder lock
- Top key/shank cylinder, 5 master keys, 1 construction site key and property card for protected duplication, security card (with cylinder serial number)
- Accessory bag with everything needed for assembly

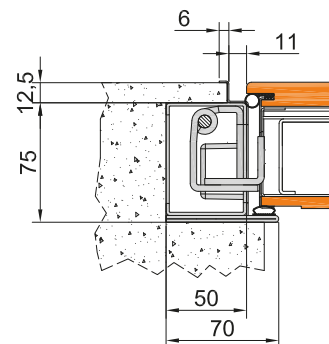

PRESTAZIONI	Performance	1 ANTA
Acustica	Acoustics	36 dB
Termica	Thermal	1,6 W/m <sup>2</sup> K
Aria	Air	2
Acqua	Water	2
Vento	Wind	3
Antieffrazione	Anti-burglary	3



# CARATTERISTICHE TECNICHE TECHNICAL CHARACTERISTICS

## TELAIO E CONTROLAIO/ FRAME AND COUNTERFRAME

STANDARD  
STANDARD

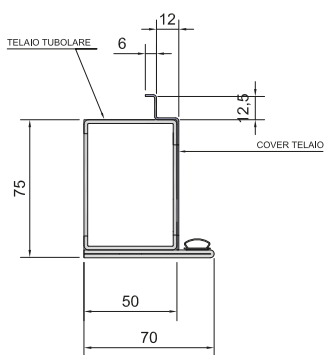

TELAIO CON COVER  
FRAME AND COVER

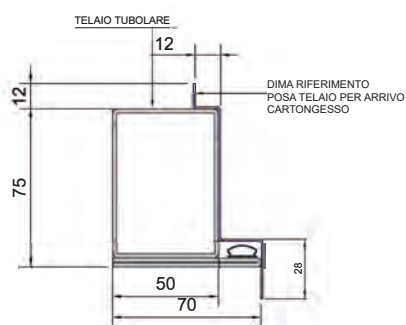

TELAIO CON CASSAMATTA  
FRAME WITH CHEST

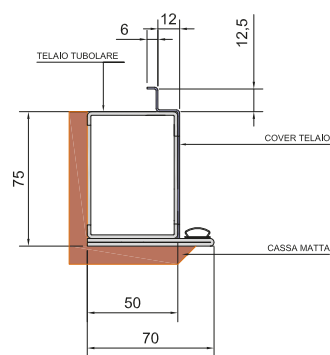

## INSTALLAZIONE IN LUCE (TELAIO STANDARD) / BETWEEN WALL INSTALLATION (STANDARD FRAME)

Misura da rilevare: Foro muro esterno (Dfe)  
Battuta interna dx e sx min 75 mm

$L_{Ln}$  (luce netta in larghezza) =  $L_{Dfe}$  (larghezza foro muro esterno)

$H_{Ln}$  (luce netta in altezza) =  $H_{Dfe}$  (altezza foro muro esterno)

Necessary measures: External wall opening (Dfe)  
Internal jamb RH and LH min 75 mm

$L_{Ln}$  (net passage W) =  $L_{Dfe}$  (external wall opening W)

$H_{Ln}$  (net passage H) =  $H_{Dfe}$  (external wall opening H)

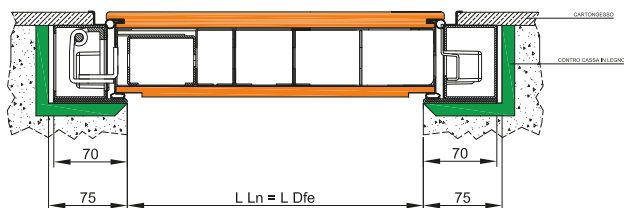

SEZIONE ORIZZONTALE  
HORIZONTAL SECTION

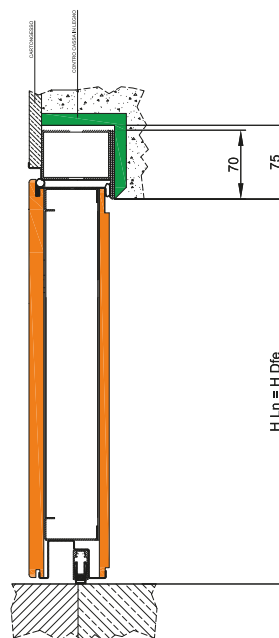

SEZIONE VERTICALE  
VERTICAL SECTION

# FLAMMA 60

## CARATTERISTICHE TECNICHE TECHNICAL CHARACTERISTICS

### CHIUSURE DI SICUREZZA

- N° 1 deviatore doppio laterale superiore
- N° 1 deviatore doppio laterale inferiore
- N° 6 rostri fissi
- N° 4 rostri attivi

### CARATTERISTICHE TECNICHE

- SCocca in doppia lamiera elettrozincata spessore 12/10 con tre rinforzi ad omega verticali spessore 12/10, tutto interamente puntato e saldato. Viene inserita una piastra di protezione serratura 30/10 in lamiera antitrapano, coibentata con polistirene.
- TELAIO TUBOLARE da 20/10 di spessore, verniciato a polveri termoindurenti nella tinta simil RAL 7016 (grigio antracite).
- CERNIERE a scomparsa regolabili, applicazione della terza cerniera su porte con H > 2200 mm
- DIMENSIONI MASSIME 900 mm X 2300 mm
- PESO anta + telaio = 120 Kg ca.

### DOTAZIONI DI SERIE

- Carenatura fermapannello esterno in acciaio inox AISI 304 satinato
- Soglia mobile con lama para aria a ghigliottina autolivellante per chiusura a pavimento (fig. MT001)
- Defender antitubo con trattamento PVD
- Registro scrocco cromato regolabile montato sul telaio
- Guarnizione ad alte prestazioni sul telaio
- Serratura a cilindro europeo
- Cilindro Top chiave/codolo, 5 chiavi padronali, 1 chiave cantiere e Card di proprietà per duplicazione protetta, Card di sicurezza (con numero seriale del cilindro)
- Pompa chiudiporta idraulico per garantire l'autochiusura

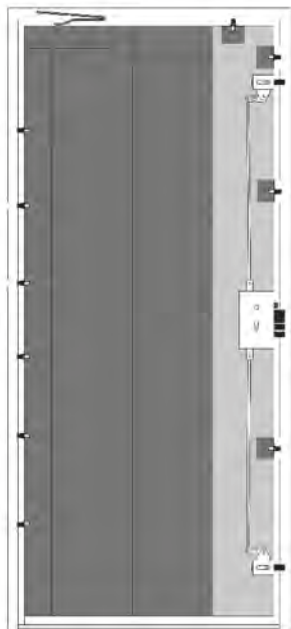

### MULTIPOINT SECURITY LOCKS

- N° 1 upper double lateral diverter
- N° 1 lower double lateral diverter
- N° 6 fixed rostrums
- N° 4 active rostrums

### TECHNICAL CHARACTERISTICS

- SHELL in double electrogalvanized sheet thickness 12/10 with three vertical omega reinforcements thickness 12/10, all entirely pointed and welded. A 30/10 lock protection plate in sheet metal is inserted antitrapano, insulated with polystyrene.
- TUBULAR FRAME 20/10 thick, painted with thermosetting powders in the color similar to RAL 7016 (anthracite gray).
- Adjustable concealed hinges, application of the third hinge on doors with H > 2200 mm
- MAXIMUM DIMENSIONS 900 mm X 2300 mm
- DOOR WEIGHT + frame = 120 Kg approx.

### STANDARD SETTINGS

- External panel fairing in satin AISI 304 stainless steel
- Mobile threshold with self-leveling guillotine air shield for floor closure (fig. MT001)
- Anti-pipe defender with PVD treatment
- Adjustable chrome latch register mounted on the frame
- High performance gasket on the frame
- European cylinder lock
- Top key/shank cylinder, 5 master keys, 1 construction site key and property card for protected duplication, security card (with cylinder serial number)
- Hydraulic door closer pump to ensure self-closing

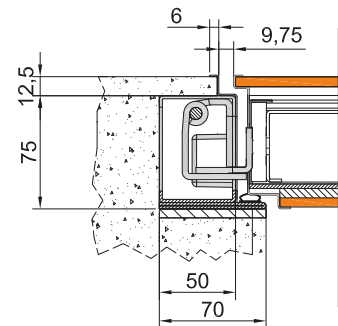

PRESTAZIONI	Performance	1 ANTA
Acustica	Acoustics	41 dB
Termica	Thermal	1,8 W/m <sup>2</sup> K
Aria	Air	4
Acqua	Water	6B
Vento	Wind	2
Antieffrazione	Anti-burglary	3

# CARATTERISTICHE TECNICHE TECHNICAL CHARACTERISTICS

## TELAIO E CONTROLAIO/ FRAME AND COUNTERFRAME

STANDARD  
STANDARD

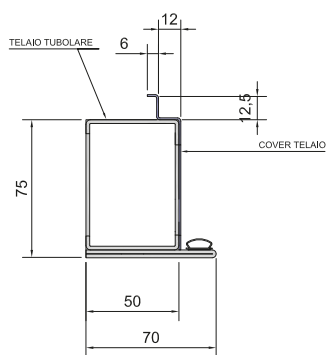

TELAIO CON COVER  
FRAME AND COVER

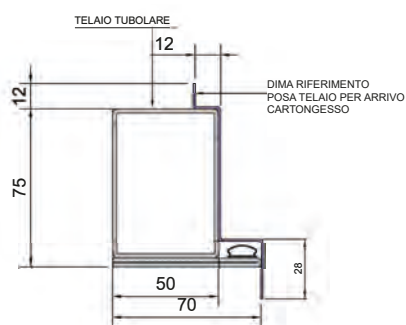

TELAIO CON CASSAMATTA  
FRAME WITH CHEST

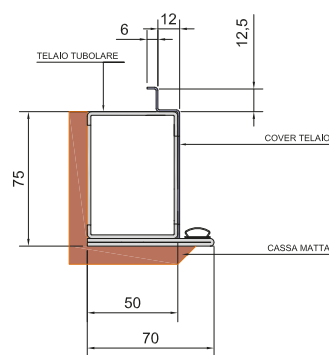

## INSTALLAZIONE OLTRE LUCE (TELAIO STANDARD) / BEHIND WALL INSTALLATION (STANDARD FRAME)

Misura da rilevare: Foro muro esterno (Dfe)  
Battuta interna dx e sx min 75 mm

$L_{Ln}$  (luce netta in larghezza) =  $L_{Dfe}$  (larghezza foro muro esterno)

$H_{Ln}$  (luce netta in altezza) =  $H_{Dfe}$  (altezza foro muro esterno)

Necessary measures: External wall opening (Dfe)  
Internal jamb RH and LH min 75 mm

$L_{Ln}$  (net passage W) =  $L_{Dfe}$  (external wall opening W)

$H_{Ln}$  (net passage H) =  $H_{Dfe}$  (external wall opening H)

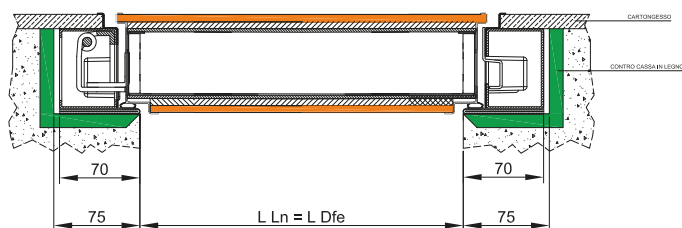

SEZIONE ORIZZONTALE  
HORIZONTAL SECTION

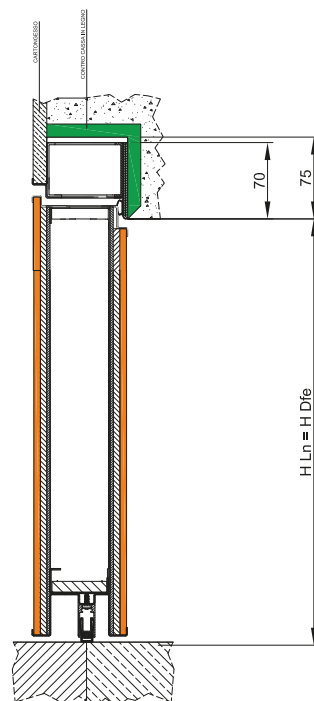

SEZIONE VERTICALE  
VERTICAL SECTION



I nostri cataloghi sono stampati  
su carta ecologica certificata FSC

Our catalogs are printed  
on FSC certified ecological paper

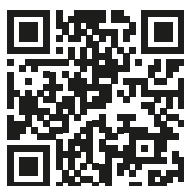

**SILVELOX**  
GROUP SPA

**SILVELOX GROUP SPA**

**Headquarters and Production plant:**

Viale Venezia, 37 I-38050 Castelnuovo - Trento - Italy  
Tel. (+39) 0461 755 755 - Fax (+39) 0461 752 466  
info@silvelox.it - silvelox@cg.legalmail.it - www.silvelox.it

**Production plant:**

Via Rossi, 14 I-25010 Remedello - Brescia - Italy  
Tel. (+39) 030 258 5500 - Fax (+39) 030 258 2537  
seip@silvelox.it - www.seipdoors.it

 **GreenPea**  
from ideas to products

 **VAISUGANA**  
LAGORAI  
GSTC