

SILVELOX
OPEN YOUR SPACE

PERSEO



Lucrezia Lamberti

SILVELOX

OPEN YOUR SPACE

Silvelox crea porte uniche con maestria artigianale come opere d'arte che portano valore alla casa.

Silvelox creates unique doors with craftsmanship ability, like artworks, that give value to the house.

COLORE IN CITTÀ
tempera su tela
50x40 cm - 2020
Lucrezia Lamberti

COLOR IN THE CITY
tempera on canvas
50x40 cm - 2020
by Lucrezia Lamberti

PERSEO

Prestazioni tecniche superiori e ricercata cura dei dettagli sono gli elementi distintivi della porta d'ingresso Perseo.

La dotazione della cerniera a scomparsa, brevettata da Silvelox consente l'apertura dell'anta a 135 gradi e crea un effetto coplanare tra pannello interno e telaio incorniciato.

Esclusivi standard di qualità, accostati alla Classe 4 di sicurezza si uniscono alle lavorazioni artigianali del pannello in grado di adattarsi a diversi stili architettonici fino alla massima personalizzazione e il sistema Secur Therm, a tripla battuta garantisce performance tecniche elevate.

Superior technical performance and refined attention to detail are the distinctive elements of the Perseo entrance door.

The concealed hinge, patented by Silvelox, allows the door to open at 135 degrees and creates a coplanar effect between the inner panel and the framed frame.

Exclusive quality standards, combined with the Safety Class 4 are combined with the craftsmanship of the panel able to adapt to different architectural styles up to the maximum customization and the Secur Therm system, with triple stop guarantees high technical performances.

CLASSE 4 ANTIEFFRAZIONE
ISOLAMENTO TERMICO $U=1,20 \text{ W/M}^2\text{K}$
CERNIERA A SCOMPARSA
PRODOTTO VERSATILE
SOLUZIONI VETRATE

CLASS 4 ANTI-BURGLARY
THERMAL INSULATION $U=1,20 \text{ W/M}^2\text{K}$
HIDDEN HINGES
MULTIPLE CONFIGURATION POSSIBILITIES
GLAZED SOLUTIONS



PERSEO
Family Metal Skin
Modello Liscio
con laterale vetrato
Effetto peltro bronzo

PERSEO
Family Metal Skin
Model Liscio
with side glazed
Pewter effect bronze

LE UNICITÀ DI PERSEO

UNIQUE POINTS OF DISTINCTION PERSEO

PERSEO
Family Design
a disegno
con laterali vetrati
Rame

PERSEO
Family Design
to drawing
with side glazed
Copper



4 SICUREZZA classe SECURITY class

Il livello di protezione della Classe 4 garantisce la resistenza della porta a tentativi di scasso rumoroso ed insistente da parte di uno scassinatore esperto che può utilizzare anche trapani, seghe, asce, martelli ecc. è indicata per ingressi principali di ville, case isolate o negozi a particolare rischio di scasso.

Protection level assures the highest levels of security against break in, made by an expert burglar that could also use drills, saws, hatches, hammer etc. They are particularly suitable for main entrances of villas, detached houses or shops at risk.



CERNIERE A SCOMPARSA BREVETTO ESCLUSIVO SILVELOX

HIDDEN HINGES EXCLUSIVE PATENT SILVELOX

La dotazione della cerniera a scomparsa consente l'apertura dell'anta a 135 gradi e crea un effetto coplanare tra pannello interno e telaio incorniciato.

The concealed hinge allows the door to open at 135 degrees and creates a coplanar effect between inner panel and framed frame.

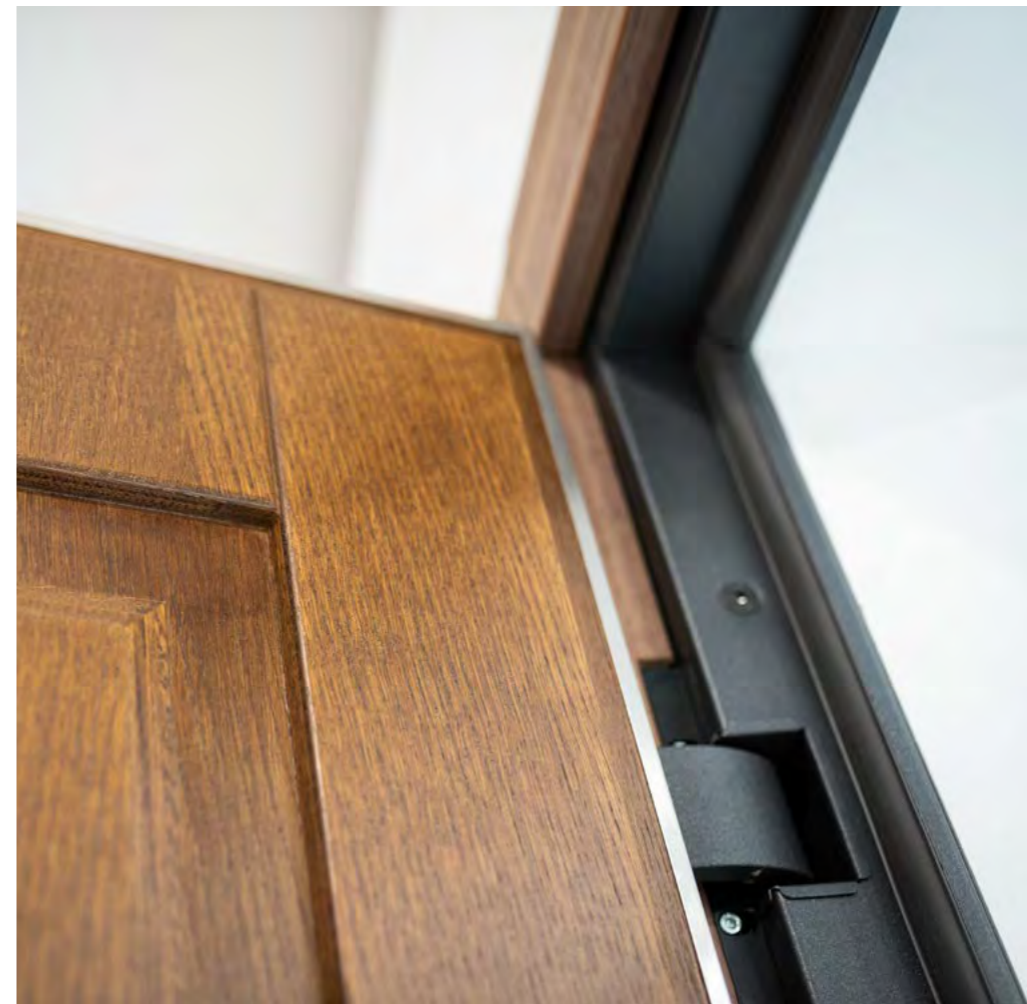

SISTEMA CILINDRI DI SICUREZZA

CILINDRO:
 • 5 chiavi padronali
 • 1 chiavi cantieri
 • Carta di sicurezza
 • Certificazione: Grado 6 (massimo grado) secondo EN 1303
 • SKG ★★★

SAFETY CYLINDERS SYSTEM

CYLINDER:
 • 5 master keys
 • 1 building site key
 • Security card
 • Certification: Grade 6 (maximum grade) according to EN 1303
 • SKG ★★★

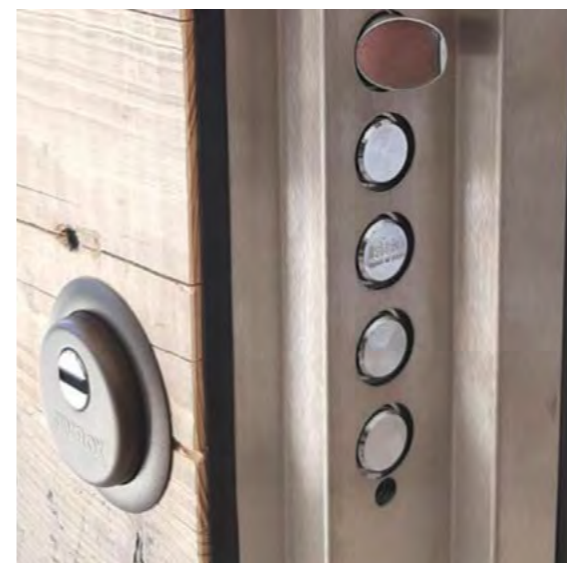

SOLUZIONE CON ANTA COMPLEMENTARE RIVESTITA IN LEGNO

SOLUTION WOOD FRAME COMPLEMENTARY DOOR

È possibile avere una versione che nello studio progettuale coniuga rigore prestazionale e una esaltazione particolare della rifinitura in legno della porta con la finitura dell'anta in legno che è ripresa nel profilo del battente dove sono annegate le gabbiette dei rostri.

It is possible to have a version that in the design study combines performance rigor and a particular exaltation of the wooden finish of the door with the finish of the wooden door which is reproduced in the profile of the leaf where the cages of the bolts are embedded.

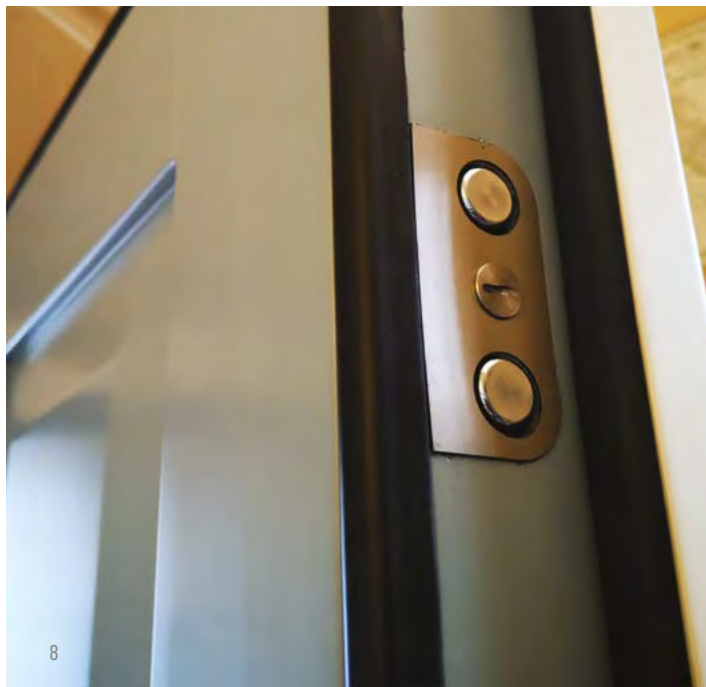

ALTE PRESTAZIONI STANDARD STANDARD HIGH PERFORMANCES



Isolamento termico
con indice di trasmittanza
termica $U=1,2 \text{ W/m}^2\text{K}$

Thermal insulation
 $U=1,2 \text{ W/m}^2\text{K}$



Acqua classe 2
Aria classe 2
Vento classe 3

Water resistance class 2
Air sealing class 2
Wind resistance class 3



Abbattimento
acustico
a 40 dB

Noise reduction
40 db



Classe 4
antiefrazione

Class 4 security
certification

PRESTAZIONE MIGLIORATIVE
A RICHIESTA

PERFORMANCE IMPROVEMENTS
ON DEMAND

BORDATURA PANNELLO
INTERNO IN LEGNO
IN TINTA CON
PANNELLO INTERNO
DA 10 MM DI SPESSORE

INTERNAL WOODEN TRIMS
MATCHING 10MM THICK
INTERNAL PANEL



PERSEO
Family Monofresata
Modello P104
Okoumé laccato Ral 7016

PERSEO
Family Monofresata
Model P104
Okumé lacquered RAL 7016

FILO GLASS PERSEO

LATERALE E SOPRALUCE VETRATO COMPLANARE

Soluzione unica di Silvelox con porta per garage
e porta d'ingresso abbinata con stessa estetica e finitura.

FLUSH LATERAL GLASS PANEL AND TRANSOM WINDOW

Silvelox unique solution with garage and entrance door combined
with the same aesthetic and finishing.



Dettaglio coplanarietà
pannello con fascione
e laterale filo glass

Detail of coplanarity
between filoglass glazed
lateral, fascia board
and door panel

Porta per garage Secur
Family Design
Modello Frame 4
Larice spazzolato nero

Secur garage door
Family Design
Model Frame 4
Brushed larch Black

PERSEO
Family Design
Modello Frame 4
Larice spazzolato nero

PERSEO
Family Design
Model Frame 4
Brushed larch Black

GLASS PERSEO

LATERALE E SOPRALUCE
VETRATO COMPLANARE

COPLANAR TIMBER COVERED LATERAL
GLAZED AND TRANSOM WINDOW



PERSEO
Family Linee
Modello Geo
con laterale vetrato
Okoumé laccato Ral 7016

PERSEO
Family Linee
Model Geo
with side glazed
Okoumé lacquered RAL 7016

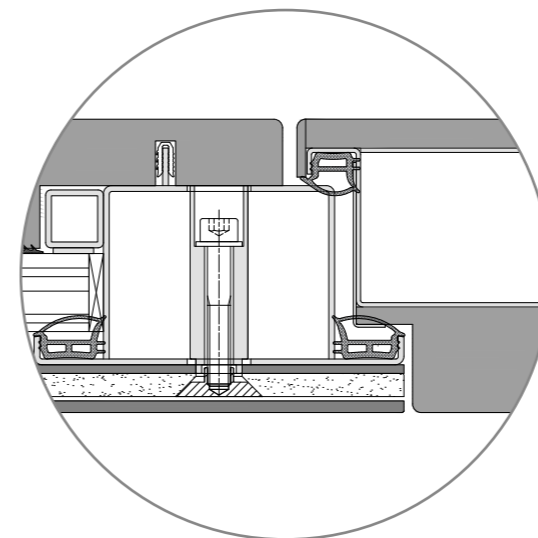

Doppia guarnizione
Double seal



Dettaglio complanarità tra vetro e battente
Detail co planarity between glass and leaf

La porta blindata si unisce ad un laterale fisso o sopra luce vetrato che sul lato esterno sposa il rigore del design estremo, montando un vetro retro verniciato sulla struttura complanare al battente della porta. L'esaltazione progettuale si esprime oltre che nella complanarità tra vetro, fascione e estetico pannello, anche nel sistema di montaggio del vetro retro verniciato che avviene a filo del telaio della porta.

Il laterale fisso o sopra luce vetrato GLASS è disponibile con vetro retro verniciato nelle finiture stop sol grigio e stop sol bronzo.

The steel clad-door combines with a glazed fixed lateral or transom window that on the external side marries the strictness of the extreme design, mounting a back varnished glass on the coplanar leaf structure of the door. The planning exaltation is reached, in addition to the co planarity between glass, fascia and panel's aesthetics, also in the assembly system of the back varnished glass that it's installed flush with the door's frame.

The fixed lateral or transom window GLASS is available with back varnished glass in stop sol version grey and bronze in the following configurations.



Esempi di soluzioni vetrate glass
Examples of glass glazing solutions

SOLUZIONI VETRATE GLAZED SOLUTIONS



PERSEO
Family Linée
Modello Geo
con laterale vetrato
Okoumé laccato Ral 7031

PERSEO
Family Linée
Model Geo
with side glazed
Okoumé lacquered Ral 7031

SOLUZIONI VETRATE GLAZED SIDE LIGHTS

Soluzioni di immagine ed eleganza in grado di valorizzare l'ambiente inserendo superfici vetrate in diverse forme e dimensioni sia nel battente che come laterali o sopra- e vetrati, assecondando le richieste più difficili per un design esclusivo nel rispetto della sicurezza.

CLASSE 3 - VETRO STRATIFICATO
Composizione del vetro: 6 + 6 + 2,8 (pvb) + 10 (camera) + 3 + 3 + 0,38 (pvb) vetrocamera con nuovo sistema per la riduzione della condensa interna.

CLASSE 4 - VETRO STRATIFICATO
Composizione del vetro: 8 + 8 + 4,5 (pvb) + 6 (camera) + 3 + 3 + 0,38 (pvb) vetrocamera con nuovo sistema per la riduzione della condensa interna.

Glass panels can be installed both in the leaf and as lateral or glazed transom, complying with the most difficult requests for an exclusive design whilst maintaining security standards.

CLASS 3 - MULTILAYER GLASS
Glass composition: 6 + 6 + 2,8 (pvb) + 10 (airspace) + 3 + 3 + 0,38 (pvb) double glazing with new system for internal condensation reduction.

CLASS 4 - MULTILAYER GLASS
Glass composition: 8 + 8 + 4,5 (pvb) + 6 (airspace) + 3 + 3 + 0,38 (pvb) double glazing with new system for internal condensation reduction.



Dettaglio sopra- e vetrato
Fanlight detail inside view



Liscio trasparente temprato
Flat transparent



Satinato bianco temprato
Satin white



Goffrato chiaro
Light embossed



Specchiato temprato
Flat reflective

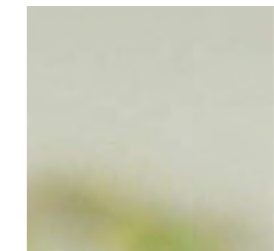

Satinato bronzo temprato
Satin bronze



Trasparente grigio o stop sol
Transparent grey

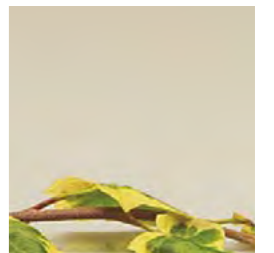

Trasparente bronzo o stop sol
Transparent bronze

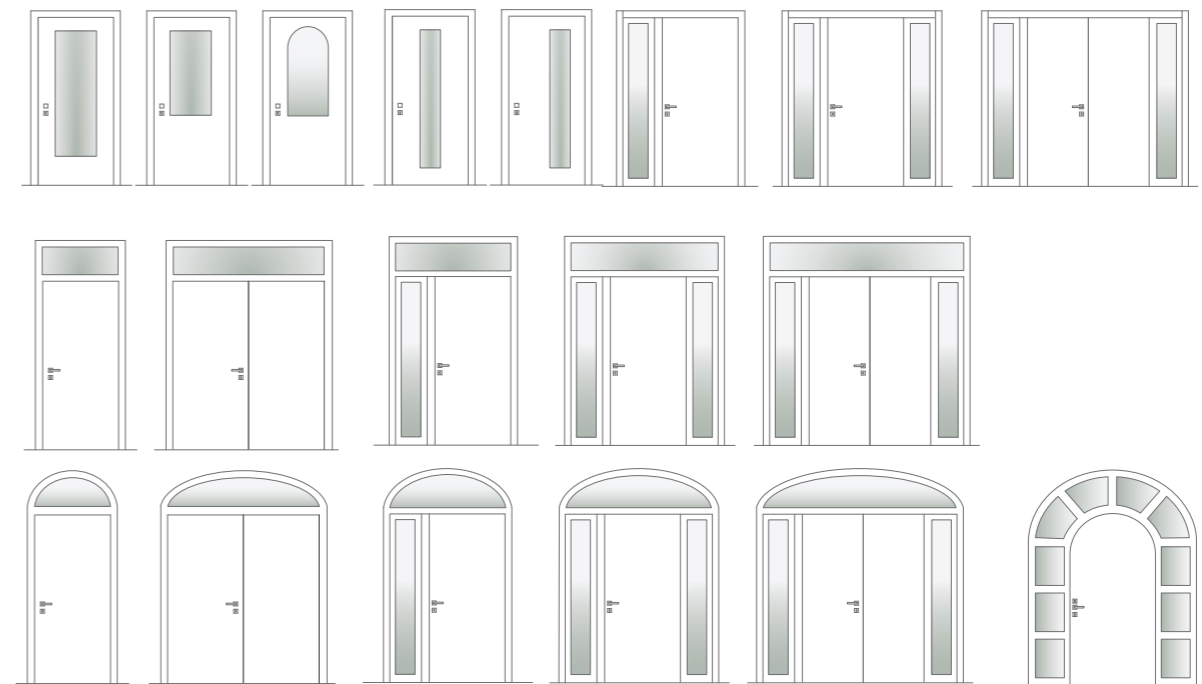

Esempi di soluzioni vetrate / Examples of glazed solutions

PERSEO

RIVESTIMENTI COVERINGS

La scelta dei materiali parte da soluzioni in **HDF** per il pannello interno. Un pannello composto da fibre di legno aggregate a secco con leganti a base di resine termoidurenti.

Proposte di maggior pregio e maggiormente caratterizzanti la storicità artigianale di Silvelox sono i pannelli per il lato esterno in **MULTISTRATO CON SUPERFICIE IN ESSENZA** decorativa e i pannelli in **MULTISTRATO MARINO DI OKOUMÉ MASSELLATO E NOBILITATO IN ESSENZA**. Il tipo di costruzione di questi pannelli permette l'incisione a pantografo e la lavorazione in falegnameria oltre che la verniciatura con ciclo all'acqua. La soluzione di nobilitarlo con tranciati nobili di essenza permette la selezione e l'allineamento delle venature per un risultato di pregio.

L'UNICITÀ DELLA VERNICIATURA FATTA A MANO

Il pannello in multistrato marino di Okoumé o in HDF segue il processo di laccatura delle finiture **METAL SKIN** che prevede una lavorazione manuale per ricreare l'effetto del metallo nelle finiture petro e patinato.

Soluzioni di maggior tendenza sono i pannelli **MATERIA** costituiti da una superficie di Laminam.

The choice of the materials starts from solutions in **HDF** for the inner panel. A panel made up of dry wood fibers aggregated with thermosetting resins based binders.

Proposals of greater value and that more characterize the artisan historicity of Silvelox are the panels for the outer side **HARDWOOD PLYWOOD** panels and the **WOOD VENEER MARINE OKOUMÉ PLYWOOD PANELS**. The particular composition of these panels allows pantograph engraving and carpentry process, as well as water cycle painting. The nobilitation through hardwood plywood boards allows the selection and alignment of the grains, for a valuable result.

THE UNIQUENESS OF HANDMADE PAINTING

Okoumé as well as **HDF** wood veneer marine plywood panels follow the lacquering process of **METAL SKIN** finishings, which provide a manual processing to reproduce the metal effect in the pewter and glazed finishing.

Most trendy solutions are the **MATERIA** panels, made of a Laminam surface.

PERSEO
Family Metal Skin
Modello Geo
Effetto petro Ferro

PERSEO
Family Metal Skin
Model Geo
Pewter effect Iron



PERSEO
Family Linee
Modello Newman
Abete nodato
tinta a campione

PERSEO
Family Linee
Model Newman
Knotted fir
in sample color



PERSEO
Family Bugne
Modello Ego
Okoumé laccato
RAL S 3005-G50Y

PERSEO
Family Bugne
Model Ego
Okoumé lacquered
RAL S 3005-G50Y



PERSEO
Family Lisci
Modello Zenith
HDF laccato Ral 7039

PERSEO
Family Lisci
Model Zenith
HDF lacquered RAL 7039



PERSEO
Family Materia
Modello Liscio
Stone grigio chiaro

PERSEO
Family Materia
Model Liscio
Light grey Stone



PERSEO
Family Design
Modello Frame 4
Larice spazzolato naturale

PERSEO
Family Design
Model Frame 4
Brushed larch natural



PERSEO
Family Japanese
Modello Wabi Sabi
Legno invecchiato
selezionato dal cliente

PERSEO
Family Japanese
Model Wabi Sabi
Aged wood selected
by the customer



PERSEO
Family Design
Modello Millerighe
Rovere naturale

PERSEO
Family Design
Model Millerighe
Natural oak



PERSEO
Family Alluminio
Modello 2110
Opaco 3005 Rosso vino

PERSEO
Family Alluminio
Model 2110
Matt 3005 Whine Red

PERSEO
Family Materia
Modello Piano
Marmo Bianco

PERSEO
Family Materia
Model Piano
White Marble



PERSEO
Family Design
Modello Piana
Materia Arenaria
Sud Africa

PERSEO
Family Design
Model Piana
Materia Arenaria
Sud Africa



PERSEO
Family Design
Modello Layer Line
Okoumé laccato Grigio platino 7036

PERSEO
Family Design
Model Layer Line
Okoumé Laquered grey Platinum 7036



FAMILY LISCI

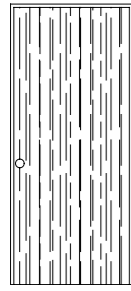

MODELLO
ZENITH

Pannello in fibra di legno alta densità **HDF**. Spessore 6 mm o 10 mm. Completo di angolari fermapannello se previsto per lato interno porta.

HDF High density fiber wood panel. Thickness 6 mm or 10 mm. Complete with panel corner holder if provided for the inside of the door.

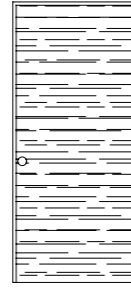

MODELLO
LINE

Pannello multistrato con superficie in essenza. Spessore 10 mm con pannello bordato. **Pannello multistrato marino nobilitato in essenza.** Spessore 10 mm con pannello bordato.

Hardwood Plywood. Thickness 10 mm, edged panel.

Wood veneer marine plywood. Thickness 10 mm, edged panel.

FAMILY LINEE

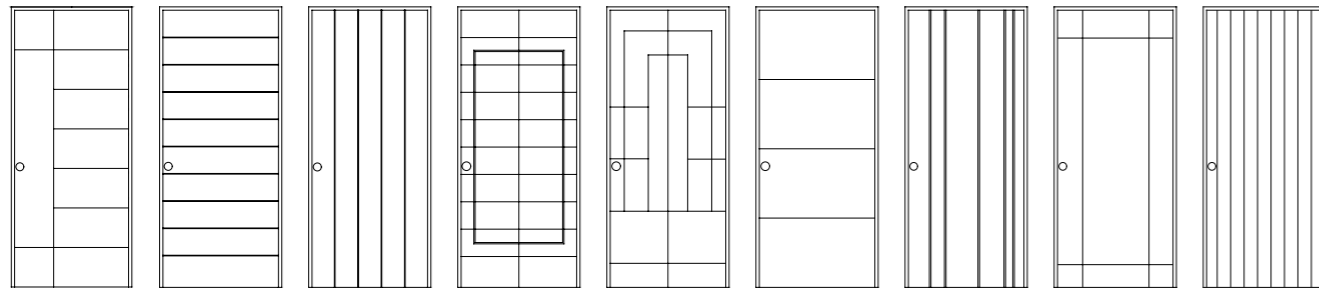

MODELLO
GEO

MODELLO
FOR

MODELLO
VIP

MODELLO
ZEN

MODELLO
ARA

MODELLO
TRIO

MODELLO
NEWMAN

MODELLO
QUADRA

MODELLO
DOC

Pannello in fibra di legno alta densità **HDF** o **pannello multistrato con superficie in essenza** o **pannello multistrato marino nobilitato in essenza**. Spessore 10 mm con pannello bordato.

HDF High density fiber wood panel or hardwood plywood panel or wood veneer marine plywood panel. Thickness 10 mm, edged panel.

FAMILY BUGNE

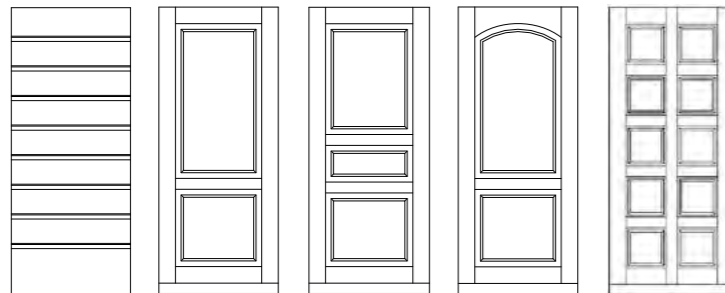

MODELLO
OLD

MODELLO
BIG

MODELLO
EGO

MODELLO
ARC

MODELLO
TOP

Pannello in fibra di legno alta densità **HDF** o **pannello multistrato con superficie in essenza** o **pannello multistrato marino e nobilitato in essenza**. Spessore 15 mm con pannello bordato.

HDF High density fiber wood panel or hardwood plywood panel or wood veneer marine plywood panel. Thickness 15 mm with edged panel

FAMILY MONOFRESATA

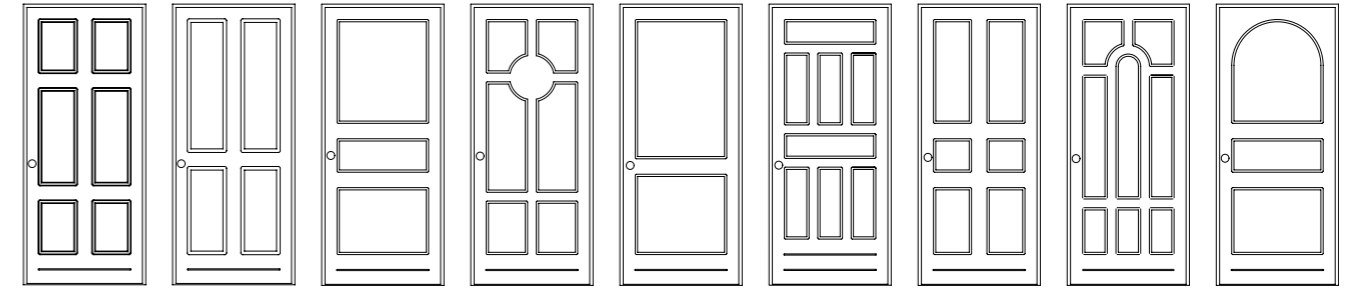

MODELLO
P 100

MODELLO
P 101

MODELLO
P 104

MODELLO
P 106

MODELLO
P 115

MODELLO
P 117

MODELLO
P 118

MODELLO
P 120

MODELLO
P 121

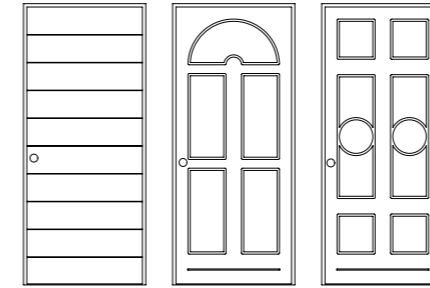

MODELLO
P 122

MODELLO
P 125

MODELLO
P 131

Pannello in fibra di legno alta densità **HDF** o **pannello multistrato con superficie in essenza**. Spessore 14 mm con pannello bordato.

HDF High density fiber wood panel or hardwood plywood panel. Thickness 14 mm with edged panel

FAMILY JAPANESE MOOD

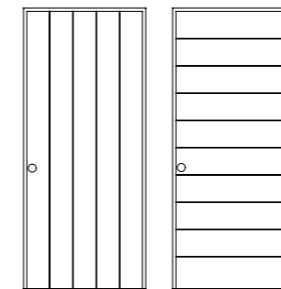

MODELLO
VIP

MODELLO
FOR

FAMILY MATERIA

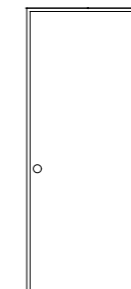

MODELLO
LISCIO

FAMILY DESIGN

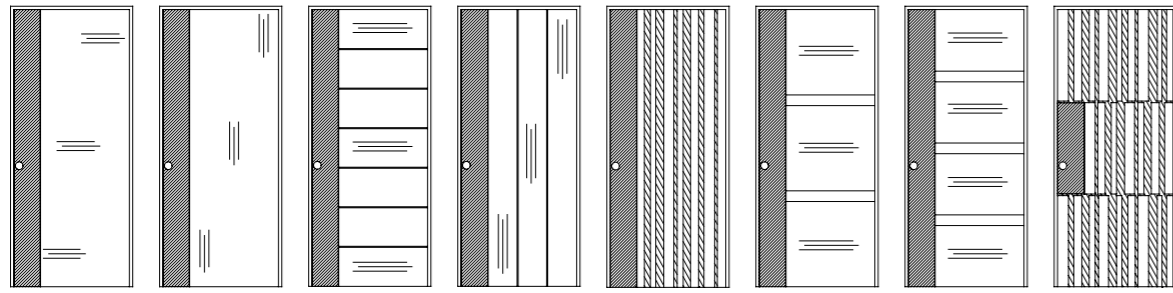

MODELLO FLAT LINE MODELLO FLAT ZENITH MODELLO LAYER LINE MODELLO LAYER ZENITH MODELLO RANDOM* MODELLO FRAME 3 MODELLO FRAME 4 MODELLO MATRIX*

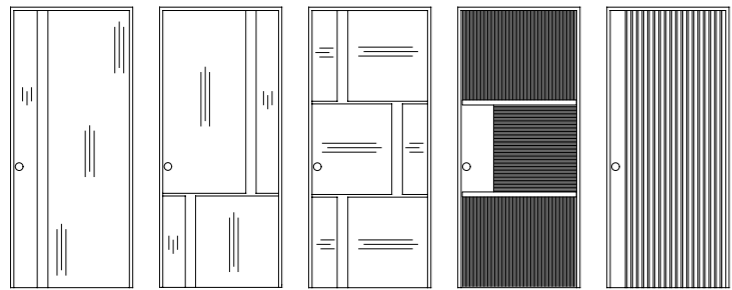

MODELLO SLOT 1 ZENITH MODELLO SLOT 2 ZENITH MODELLO SLOT 3 ZENITH MODELLO ONDULÈ MODELLO MILLERIGHE*

Pannello in fibra di legno alta densità **HDF** o pannello **multistrato con superficie in essenza** o pannello **multistrato marino nobilitato in essenza**. Spessore 15 mm.

HDF High density fiber wood panel or **hardwood plywood panel** or **wood veneer marine plywood panel**. Thickness 15 mm.

* Disponibile solo nelle finiture Okoumé, HDF e rovere impregnato/naturale.
* Available only in the finishes Okoumé, HDF and oak impregnated/natural.

FAMILY METAL SKIN

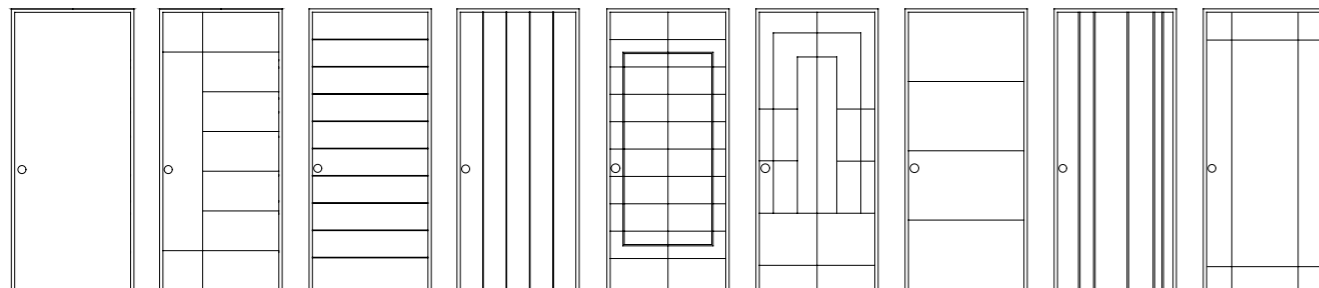

MODELLO LISCIO MODELLO GEO MODELLO FOR MODELLO VIP MODELLO ZEN MODELLO ARA MODELLO TRIO MODELLO NEWMAN MODELLO QUADRA

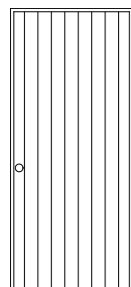

MODELLO DOC

Il **pannello in multistrato marino di Okoumé** o in **HDF** segue il processo di laccatura delle finiture Metal skin che prevede una lavorazione manuale per ricreare l'effetto del metallo nelle finiture peltro e patinato. Il ciclo di verniciatura combina l'utilizzo di una base lucida con la vernice all'acqua bicomponente effetto metallo satinato, che viene poi protetta con una finitura opaca trasparente acrilica. La leggera graffiatura o spugnatura della superficie, abbinata all'applicazione di una patina invecchiante, crea movimenti e sfumature uniche e di grande impatto. Le caratteristiche del pannello su cui viene effettuata questo tipo di verniciatura ne determinano l'utilizzo se per ambienti interni (**HDF**) o ambienti esterni (**Okoumé**). Spessore disponibili 15 mm.

It is the process of obtaining a metal effect on the last layer of an **Okoumé marine plywood panel**. Perfect for external exposure. Such varnishing cycle combines a shiny base with dual water-based paint for a satin effect, which is accomplished with a thin, transparent, matt protective acrylic coating. The light scratching/spongy effect, combined with an aging patina, generates unique movements and shade of high aesthetic impact. Such effect can be also applied on **HDF** panels for interior applications. Available thicknesses 15 mm.

FAMILY ALLUMINIO

ALLUMINIO SENZA INSERTI / ALUMINIUM WITHOUT INSERTS

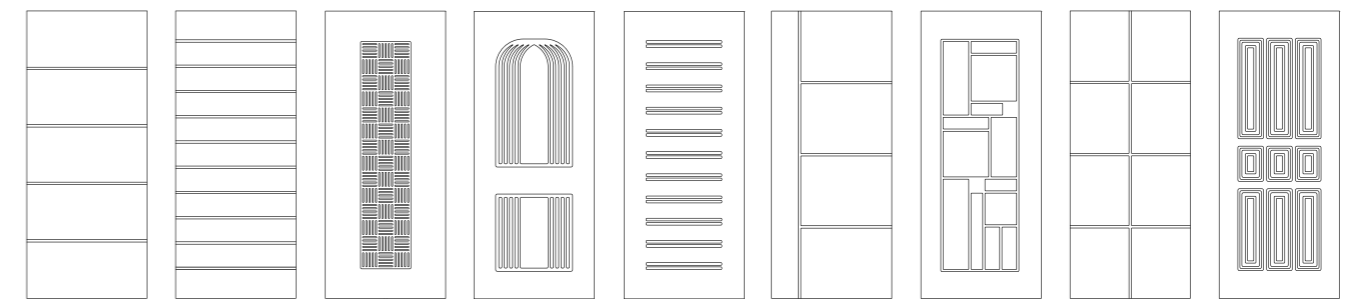

MODELLO 3200 MODELLO 3210 MODELLO 3160 MODELLO 3000 MODELLO 3030 MODELLO 3080 (DX) MODELLO 3100 MODELLO 3110 MODELLO 2030

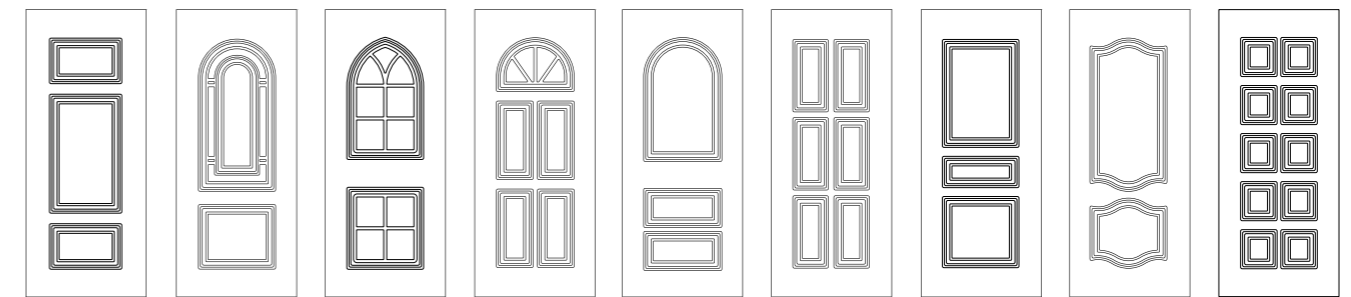

MODELLO 2040 MODELLO 2110 MODELLO 2080 MODELLO 2090 MODELLO 2130 MODELLO 2150 MODELLO 2160 MODELLO 2200 MODELLO 2020

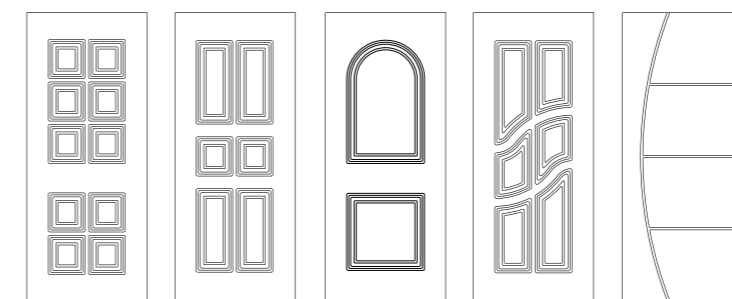

MODELLO 2022 MODELLO 2060 MODELLO 2120 MODELLO 2230 (DX) MODELLO 3090 (DX)

FAMILY ALLUMINIO

ALLUMINIO CON INSERTI / ALUMINIUM WITH INSERTS

Pannelli in alluminio con inserti in acciaio inox / Aluminum panels with stainless steel inserts

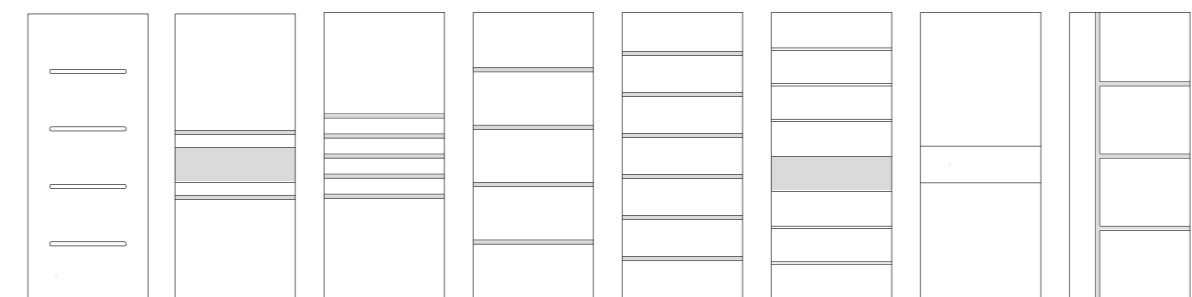

MODELLO 4100 MODELLO 4070 MODELLO 4080 MODELLO 4090 MODELLO 4100 MODELLO 4120 MODELLO 4040 MODELLO 4130 (DX)

L'ARTE DELLA LAVORAZIONE DEL LEGNO IN SILVELOX

Silvelox ha saputo fondere in un perfetto legame la passione per il legno, la maestria tradizionale, la ricerca tecnologica e la continua innovazione, creando prodotti originali e curati in ogni dettaglio, ponendo la stessa attenzione che contraddistingue il mobile d'alto artigianato. Ogni porta Silvelox è una creazione unica e artigianale, un sistema di chiusura versatile e tailor made: come un sarto, l'azienda "taglia e cuce" il prodotto su misura dei desideri del cliente, rifinandolo nei dettagli.

THE ART OF THE PROCESSING OF WOOD IN SILVELOX

Silvelox has been able to merge in a perfect bond wood passion, traditional craftsmanship, technological research and continuous innovation, creating original detailed products, placing the same attention that distinguishes high-end furniture. Each Silvelox door is a unique and artisan creation, a versatile and tailor-made closing system: like a tailor, the company "cuts and sews" the product according to the customer's wishes, refining the details.

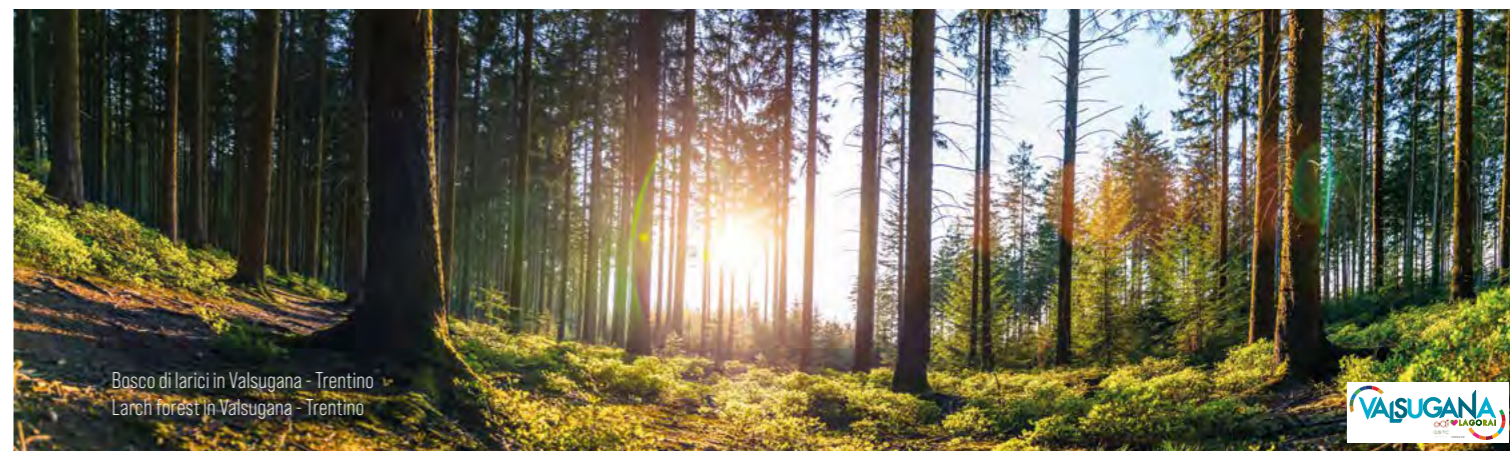

Bosco di larici in Valsugana - Trentino
Larch forest in Valsugana - Trentino



IL LEGNO / THE WOOD

LA MATERIA PRIMA CHE DA ORIGINE A TUTTE LE NOSTRE PORTE
THE RAW MATERIAL WHICH GIVES ORIGIN TO ALL OUR DOORS

OKOUMÉ / OKOUMÉ

È un legno esotico proveniente dal Gaboon in Africa occidentale dotato di buona resistenza alle sollecitazioni meccaniche e soprattutto estremamente idoneo a sopportare esposizioni gravose agli agenti atmosferici. Disponibile nella lavorazione Levigata liscia, Laccato o impregnato. Okoumé is an exotic wood which grows in Gaboon, in western Africa, with a high resistance to mechanical stress and atmospheric phenomena. Available in flat polished version, lacquered or impregnated.

ROVERE / OAK

Il Rovere è caratterizzato da belle venature, che risaltano e creano un effetto estetico molto gradevole. È un legno, proveniente principalmente da Bosnia, Serbia e Albania, molto robusto che garantisce una tenuta nel tempo di alto livello. Disponibile nella lavorazione Levigata liscia, Spazzolata o Segata. Laccato, impregnato o naturale. Oak is characterized by marked veneers, which create a very pleasant aesthetic effect. This kind of wood comes from Bosnia, Serbia and Albania, it is very strong and guarantees a high-resistance over the years. It is available in the following versions: flat, brushed, sawn. For the color: lacquered, impregnated, natural.

TEAK / TEAK

Il legno di teak è un materiale pregiato famoso in tutto il mondo proveniente da foreste tropicali e subtropicali est Asia, conosciuto per la bellezza delle venature della sua superficie e per le sue eccellenti proprietà fisiche. Disponibile nella lavorazione levigata liscia. Naturale. Teak wood is a material known everywhere around the world, it comes from the tropical and sub-tropical forests that grow in Eastern Asia. Its surface presents very pleasant veneers, besides, it has a high resistance to atmospheric agents. It is available in the polished version. Natural color.

LARICE / LARCH

Il larice è legno di pregio, compatto e robusto, è il tipico albero di montagna dell'Europa centrale e delle Alpi italiane, stabile e di buona resistenza agli agenti atmosferici. Disponibile nella lavorazione Levigata liscia o Spazzolata. Laccato, impregnato o naturale. Larch is a refined wood, characteristic of central Europe and Italian northern mountains. It is very strong and has a high-resistance to the atmospheric agents. Available in the flat or brushed version. Color: lacquered, impregnated or natural.

LARICE COTTO / AGED LARCH

Il larice cotto proveniente da Europa centrale e Alpi italiane è lavorabile come il larice normale a parte una maggiore tendenza alla scheggiatura sugli spigoli dovuta alla maggior durezza conferitagli dalla cottura. Tale durezza lo rende un po' più fragile senza però dare particolari problemi alla tenuta degli elementi di fissaggio. Aged larch coming from central Europe and Northern Italy can be worked in the same way as classical larch, but it is easier to splinter on the corners. Actually its hardness makes it more fragile compared to tender woods, nevertheless fixing elements do not present any fixing problem.

WENGÈ / WENGÈ

Il Wengè, proveniente dall'Africa equatoriale è un legno di grande impatto, per la sua conformazione, per il suo spessore, per le sfumature di colore: varia dal giallino chiaro, con venature lievemente più scure, a colorazioni intense, tendenti al marrone, con venature nere. Disponibile nella lavorazione levigata liscia e naturale. Because of its conformity, thickness, color shades, wengè is an African wood of great impression. Its color can vary from a light yellow with darker veneers to intense colors tending to brown, with black veneers. Available in the flat and natural version.

NOCE NAZIONALE E NOCE CANALETTO ITALIAN WALNUT AND CANALETTO WALNUT

Il noce nazionale è un legno molto pregiato, tra i migliori in assoluto per qualità, facilità di lavorazione e resistenza. Il legno del noce americano, conosciuto con il nome di Noce Canaletto, rispetto al Noce Europeo ha delle caratteristiche specifiche che lo contraddistinguono. Il Noce Canaletto è caratterizzato da una tonalità omogenea di marrone molto scuro e profondo con meno stonolizzazioni rispetto al noce europeo. Disponibile nella lavorazione levigata liscia e naturale. Thanks to its quality, strength and tenderness, Italian walnut is one of the most refined wood on the market. This timber has a high resistance to the machines and a medium-high stability. The American walnut timber, better known as Canaletto walnut, is different from the Italian walnut in a few specific characteristics. Available in the flat and natural version.



PANTOGRAFATURA
PANTOGRAPH



MASSELLO
WOODEN BLOCK



LEVIGATURA MANUALE
MANUAL SANDING



GIUNZIONE DEI TRANCIATI
WOODEN BOARDS JUNCTION



NOBILITAZIONE
NOBILITATION

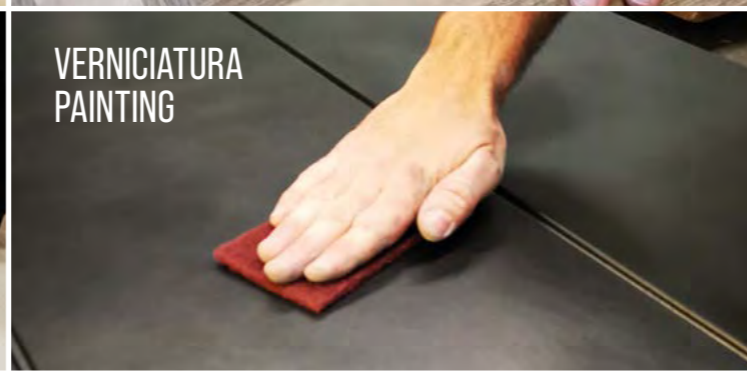

VERNICIATURA
PAINTING



INSERTI IN LEGNO
WOODEN INSERTS



FINITURA
FINISHING

LA TECNOLOGIA NELLA FINITURA SUPERFICIALE DEI PANNELLI PER LA MASSIMA GARANZIA

Ogni porta Silvelox è un prodotto unico che parte dal legno come materia prima. Il legno è un materiale vivo soggetto per sua stessa natura a mutamenti determinati da fattori esterni quali luce solare, temperatura, umidità dell'ambiente e uso quotidiano.

Le variazioni di tonalità sono normali, il legno inoltre può essere soggetto a variazioni dimensionali dipendenti dalla temperatura e dall'umidità dell'ambiente.

Nelle condizioni più critiche possono comparire lievi fessurazioni che tenderanno ad attenuarsi una volta stabilite le condizioni climatiche. È lecito aspettarsi quindi nel tempo, che le porte possano subire lievi modificazioni che, tuttavia, non producono altro effetto che aumentarne la bellezza e il fascino, proprio come avviene con ogni materiale naturale.

Un processo studiato che prevede varie fasi di verniciatura con l'ausilio di un impianto tecnologicamente avanzato, unico in Italia nel comparto delle porta d'ingresso e per garage.

PROCESSO LAVORAZIONE PANNELLI LACCATI PANELS LACQUERING PROCESS

- 1 Deposito materiale impregnante ibrido ad alta penetrazione.
Spread of high penetration hybrid impregnating material.
- 2 Passaggio nel forno a 40° circa.
Passage into the oven at 40° app.
- 3 Deposito materiale anticrepa per legni a poro aperto per uso esterno.
Spread of anti-crack material for open pore wood prepared for external use.
- 4 Passaggio nel forno a 45° circa.
Passage into the oven at 45° app.
- 5 Stuccaggio carteggiatura, preparazione alla verniciatura tutto completamente a mano.
Sanding grouting, painting preparation, all made by hand.
- 6 Deposito materiale pigmentato RAL a scelta ad alta durabilità.
Deposit of high durability RAL pigmented material.
- 7 Passaggio in forno a 45°.
Passage into the oven at 45° app.

TECHNOLOGY IN THE FINISHING OF THE PANEL SURFACE FOR THE MAXIMUM WARRANTY

All Silvelox doors are an exclusive product realized by using wood as raw material. As wood is alive, it is by nature subject to changes caused by external factors, as sun light, temperature, humidity and daily use.

Color variations are usual, furthermore wood dimensions can vary according to the temperature and humidity.

In the most critical cases it would be possible that a few slight cracks appear, but they will decrease once the wood has adapted to the temperature.

So over the years the doors may undergo slight changes, that can just increase their beauty, as per any natural material.

A studied process that provides many painting phases by using advanced technologies, the only one in Italy for what concerns the world of entrance and garage doors.

PROCESSO LAVORAZIONE PANNELLI IMPREGNATI PANELS IMPREGNATION PROCESS

- 1 Deposito impregnante colorato con preservanti per il legno top quality.
Spread of colored impregnating material with protecting substances for top quality wood
- 2 Passaggio nel forno a 40° circa.
Passage into the oven at 40° app.
- 3 Deposito fondo bagnante con assorbitori UV, top quality.
Spread of pouring primer with top quality UV absorbers.
- 4 Passaggio nel forno a 40° circa.
Passage into the oven at 40° app.
- 5 Deposito materiale colorazione tinta a scelta con lino per esterno, top quality.
Spread of top quality coloring substance with linen for external environment.
- 6 Passaggio in forno a 45°.
Passage into the oven at 45° app.



Doppia linea di verniciatura con forno a infrarossi con sette trattamenti sui pannelli Silvelox per completare la reticolazione della vernice.
Double painting line with infrared oven with 7 treatments to complete the paint fixing on Silvelox panels.

RIVESTIMENTI PER ESTERNO GARANTITI 15 E 12 ANNI

Una sequenza di processi di verniciatura personalizzati per i pannelli laccati o impregnati che hanno l'obiettivo di garantire il prodotto pannelli finito oltre la garanzia commerciale:

Pannelli in essenza impregnati
12 anni di garanzia

Pannelli in essenza laccati
15 anni di garanzia

Pannelli in essenza naturale trasparente per esterni pigmentato bianco o trasparente per interni 0 gloss 5 anni di garanzia

EXTERNAL COVERINGS 15 AND 12 YEARS WARRANTY

"A sequence of customized painting process reserved to both lacquered and impregnated panels, with the aim of guaranteeing the finished product beyond commercial warranty:

Impregnated plywood panels
12 years warranty

Lacquered plywood panels
15 years warranty

Natural transparent plywood panels for external use
White pigmented or transparent 0 gloss for internal use
5 years warranty

RIVESTIMENTI / COVERINGS

MATERIE E LAVORAZIONI / MATERIALS AND MANUFACTURE

MULTISTRATO CON SUPERFICIE IN ESSENZA //HARDWOOD PLYWOOD

Il pannello in multistrato con superficie in essenza decorativa ha uno strato dello stesso materiale e qualità dell'essenza superficiale, inserito ad una profondità predeterminata nell'ambito dello spessore finale del pannello. Grazie a questo tipo di costruzione il pannello può essere inciso al pantografo, lavorato in falegnameria e può essere verniciato con ciclo all'acqua, che esalta il colore in tutti i suoi toni e il legno nelle sue molteplici sfumature, garantendo un ottimo risultato estetico da utilizzare in tutte le applicazioni in ambienti esterni. Spessori disponibili: 10 mm, 14 mm, 15 mm.

Multi-sheets hardwood plywood panel made of wood from several essences that are visible on the surface as last layer, which provides the esthetical decoration. They are used for demanding uses. It has a high impact resistance, wall excellent surface hardness and wear-resistance, thus it is suitable for outdoor environments. Panels can be CNC machine carved and water based varnished.

MULTISTRATO MARINO MASSELLATO E NOBILITATO IN ESSENZA //WOOD VENEER MARINE PLYWOOD WITH TIMBER INSERTS

Il pannello in multistrato marino di okoumé viene lavorato al pantografo creando una traccia in base al disegno scelto dal cliente; in questo solo verrà inserito un legno massello. Successivamente il pannello viene nobilitato con tranciati nobili di essenza assemblati per mezzo di giuntatrici automatiche con una selezione da parte dell'operatore dei fogli di tranciato al fine di ottenere un ottimale allineamento delle venature. L'operatore infine provvede ad un ulteriore controllo, foglio per foglio, affinché il materiale sia privo di difettosità. Una volta ottenuto il foglio di tranciato con la qualità desiderata si esegue l'incollaggio su un pannello di okoumé. Grazie a questo tipo di costruzione il pannello può essere inciso al pantografo, lavorato in falegnameria finito con un processo di verniciatura con ciclo all'acqua, garantisce un ottimo risultato estetico da utilizzare in tutte le applicazioni in ambienti esterni. Spessori disponibili: 15 mm

Okoumé essence multi-layer marine plywood backing panels are manufactured from durable face and core veneers, with few defects so it performs longer in both humid, wet conditions and resists delaminating and fungal attack. Its construction is such that it can be used in environments where it is exposed to moisture for long periods. It is then grooved and the carves are filled by solid wood inserts that represents the highest expression of timber esthetic and performance characteristics. After being grooved veneers are applied. Visible external wood veneers are hand assembled and joint to obtain a seamless grain continuity and alignment. Craftmen/women experience, sheet by sheet quality check, his/her ability in stitching, repeated process control are crucial to obtain the requested quality that is preserved since 60 years. Available thickness: 15 mm

MULTISTRATO MARINO NOBILITATO IN ESSENZA //WOOD VENEER MARINE HARDWOOD PLYWOOD

Il pannello in multistrato marino di Okoumé viene nobilitato con tranciati nobili di essenza assemblati per mezzo di giuntatrici automatiche con una selezione da parte dell'operatore dei fogli di tranciato al fine di ottenere un ottimale allineamento delle venature. L'operatore infine provvede ad un ulteriore controllo, foglio per foglio, affinché il materiale sia privo di difettosità. L'abilità e l'attenzione dell'operatore sono fondamentali in ogni fase di questo delicato processo. Una volta ottenuto il foglio di tranciato con la qualità desiderata si esegue l'incollaggio su un pannello di Okoumé. La nobilitazione di un pannello in Okoumé è un'operazione manuale realizzata da operatori esperti nella falegnameria interna Silvelox. Grazie a questo tipo di costruzione il pannello può essere inciso al pantografo, lavorato in falegnameria e quando finito con un processo di verniciatura con ciclo all'acqua, garantisce un ottimo risultato estetico da utilizzare in tutte le applicazioni in ambienti esterni. Spessori disponibili: 10 mm, 14 mm, 15 mm

Okoumé essence multi-layer marine plywood backing panels are manufactured from durable face and core veneers, with few defects so it performs longer in both humid, wet conditions and resists delaminating and fungal attack. Its construction is such that it can be used in environments where it is exposed to moisture for long periods. Visible external wood veneers are hand assembled and joint to obtain a seamless grain continuity and alignment. Craftmen experience, ability and continuous process control are crucial to obtain the requested quality. Veneers are glued on marine plywood backing and subsequently CNC machined, varnished, moulded. Perfect for external environments applications. Available thicknesses: 10, 14, 15 mm.

METAL SKIN //METAL SKIN

Il pannello in multistrato marino di Okoumé o in HDF segue il processo di laccatura delle finiture Metal skin che prevede una lavorazione manuale per ricreare l'effetto del metallo nelle finiture peltro e patinato. Il ciclo di verniciatura combina l'utilizzo di una base lucida con la vernice all'acqua bicomponente effetto metallo satinato, che viene poi protetta con una finitura opaca trasparente acrilica. La leggera graffiatura o spugnatura della superficie, abbinata all'applicazione di una patina invecchiante, crea movimenti e sfumature uniche e di grande impatto. Le caratteristiche del pannello su cui viene effettuata questo tipo di verniciatura ne determinano l'utilizzo se per ambienti interni (HDF) o ambienti esterni (Okoumé). Spessori disponibili: 10 mm, 15 mm

Is the process of obtaining a metal effect on the last layer of an Okoumé marine plywood panel. Perfect for external exposure. Such varnishing cycle combines a shiny base with dual water-based paint for a satin effect, which is accomplished with a thin, transparent, matt protective acrylic coating. The light scratching/spongy effect, combined with an aging patina, generates unique movements and shade of high aesthetic impact. Such effect can be also applied on HDF panels for interior applications. Available thicknesses: 10, 15 mm

MATERIA //MATERIA

Il pannello in materia disponibile in due soluzioni in Laminam e Arenaria. Laminam: ovvero lastre di ceramica dal grande formato con uno spessore 3 mm, incollato su un pannello in multistrato marino di Okoumé calibrato e lavorato per arrivare allo spessore richiesto in base al modello di porta. Le caratteristiche della superficie Laminam rendono questa soluzione resistente all'usura e adatta a tutte le applicazioni in ambienti esterni. Spessori disponibili 10 mm, 18 mm
Arenaria: tappeto di pietra flessibile con finitura tattile a rilievo, composto di strati sedimentari di arenaria, su supporto di fibra naturale che ricostituiscono l'effetto reale della pietra.

The panel in matter available in two solutions in Laminam and Arenaria. Laminam: i.e. large format ceramic slabs with a thickness of 3 mm, glued onto a calibrated Okoume marine plywood panel and worked to achieve the required thickness based on the door model. The characteristics of the Laminam surface make this solution wear-resistant and suitable for all outdoor applications. Available thicknesses 10 mm, 18 mm
Arenaria: carpet of flexible stone with a tactile relief finish, composed of sedimentary layers of sandstone, on a natural fiber support that recreate the real effect of stone.

ALLUMINIO //ALUMINUM

Il pannello realizzato con lastre d'alluminio trattate con specifiche vernici anticorrosive. La lamiera esterna in alluminio con finitura ha uno spessore di 12/10 mm. La lamiera interna da 5/10 mm è liscia e ha un protettivo. Il nucleo centrale del pannello, dove poggiano le lastre d'alluminio è formato da un supporto di MDF (Medium Density Fiber) da 5 mm, questa soluzione costruttiva è adatta in tutte le applicazioni in ambienti interni, oppure da un supporto in poliuretano, è totalmente impermeabile e può essere installata anche negli ambienti più soggetti ad umidità. Sono fattibili realizzazioni a disegno che vanno a completare una gamma con più di 50 modelli. Spessori disponibili: 7 mm

The sandwich panel is composed by corrosion-resistant aluminum sheets treated with special varnishes. The finished visible surface is 12/10 mm thick. The internal non-visible one is 5/10 mm. For internal application on doors, the sheets are bonded together to contain an MDF core; for external applications, the sheets are bonded together to contain a Polyurethane core. Such panels can be customised within an overall array of 50 models. Such combination is perfect for all external environments applications. Available thickness: 7 mm.

HDF //HDF

L'HDF (High Density Fiber) è un pannello composto da fibre di legno aggregate a secco con leganti a base di resine termoidurenti. Questo moderno pannello di fibre di legno è disponibile nelle versioni liscio, pantografato nella finitura grezza o laccata da utilizzare in ambienti interni. Spessori disponibili: 6 mm, 10 mm, 14 mm, 16 mm.

High-density fiberboard (HDF) panels are fabricated by dry process, with the use of a synthetic binding material of wood fibers. It is available as smooth, CNC machine carved, unfinished or lacquered for internal use. Available thicknesses: 6, 10, 14, 16 mm.

ESSENZE / ESSENCES

PANNELLO IN MULTISTRATO CON SUPERFICIE IN ESSENZA / HARDWOOD PLYWOOD
PANNELLO IN MULTISTRATO MARINO NOBILITATO IN ESSENZA / WOOD VENEER MARINE PLYWOOD

NATURALI E DA LACCARE O IMPREGNARE / NATURAL AND TO BE LACQUERED OR IMPREGNATED

Adatto per esterni // Suitable for outdoors



Okoumé / Okoumé



Larice / Larch



Larice Spazzolato / Brushed larch



Tinta Ciliegio / Cherry colour



Tinta Mogano / Mahogany colour



Tinta Noce / Walnut Colour

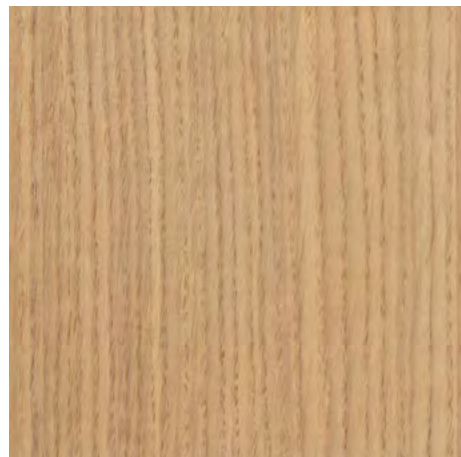

Rovere / Oak

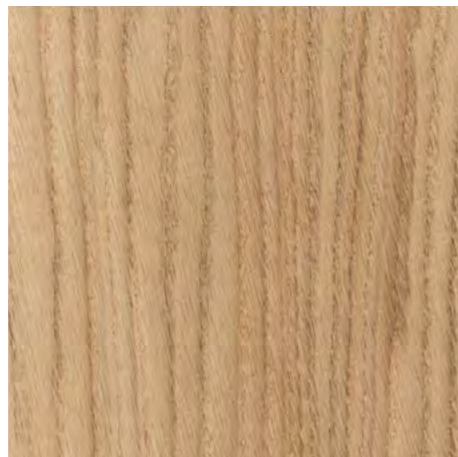

Rovere Spazzolato / rused Oak



Rovere Segato / Sawn Oak



Tinta Noce Scuro / Dark walnut colour

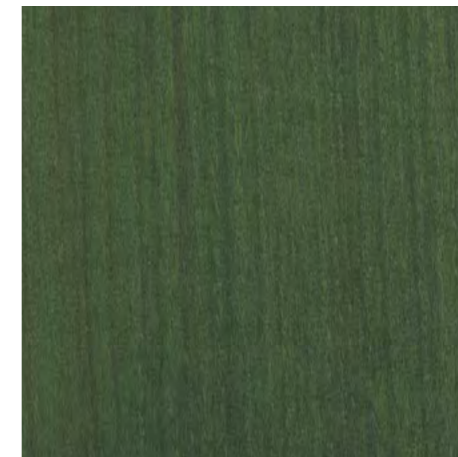

Tinta Verde / Green colour

Esempio su base Rovere ma disponibile su tutte le essenze
Example on Oak base but available on all types of wood

Trasparente per esterni pigmentato bianco - Trasparente per interni 0 gloss / White pigmented transparent for outdoor - 0 gloss transparent for indoor

DISPONIBILI NELLE FINITURE IMPREGNATE / AVAILABLE IN IMPREGNATED FINISHING

Adatto per esterni // Suitable for outdoors

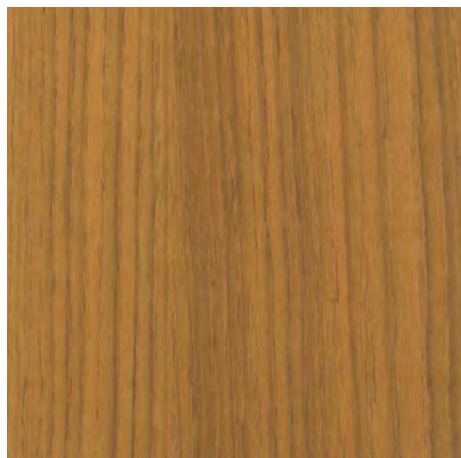

Tinta Miele / Honey colour



Tinta Rovere / Oak colour

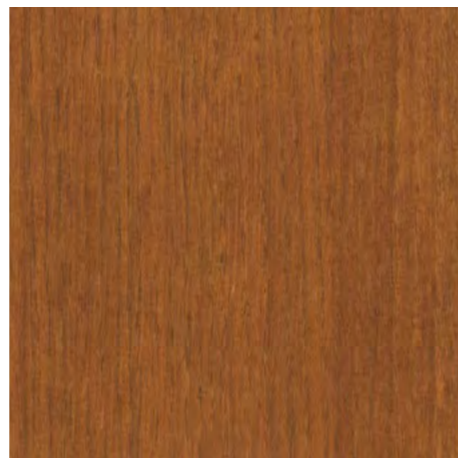

Tinta Douglas / Douglas colour

DISPONIBILI NELLE FINITURE LACCATE / AVAILABLE IN LACQUERED FINISHING

Adatto per esterni // Suitable for outdoors



RAL 1013
Bianco perla / Oyster White

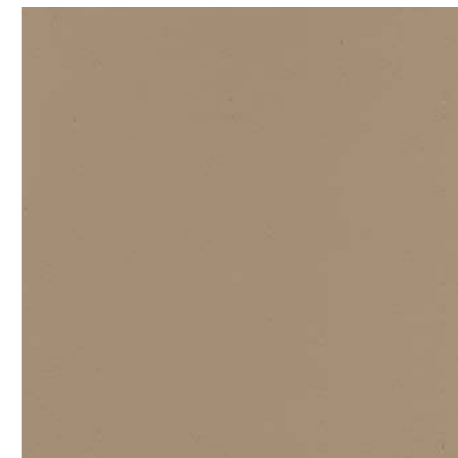

RAL 1019
Beige grigiastro / Greyish beige



RAL 3003
Rosso rubino / Ruby Red



RAL 3009
Rosso ossido / Oxide Red

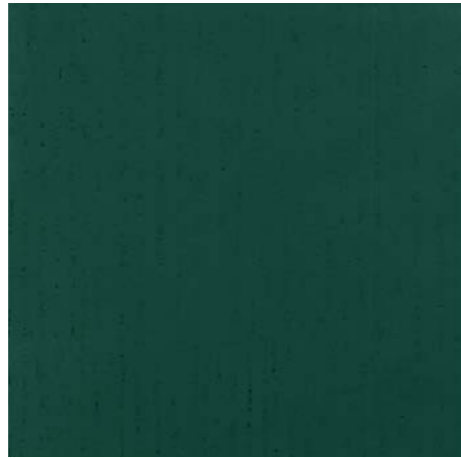

RAL 6005
Verde muschio / Moss Green



RAL 6009
Verde abete / Fir Green

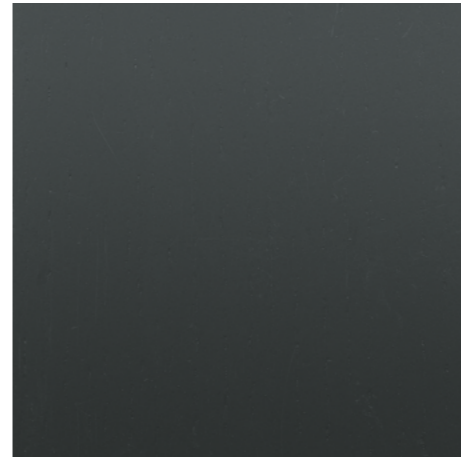

RAL 7016
Grigio antracite / Anthracite Grey



RAL 7030
Grigio pietra / Stone Grey

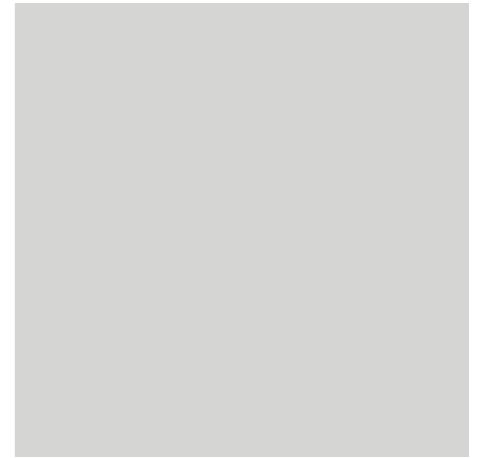

RAL 7035
Grigio luce / Light Grey



RAL 6013
Verde canna / Reed Green



RAL 6021
Verde pallido / Pale Green



RAL 7000
Grigio vaio / Squirrel Grey

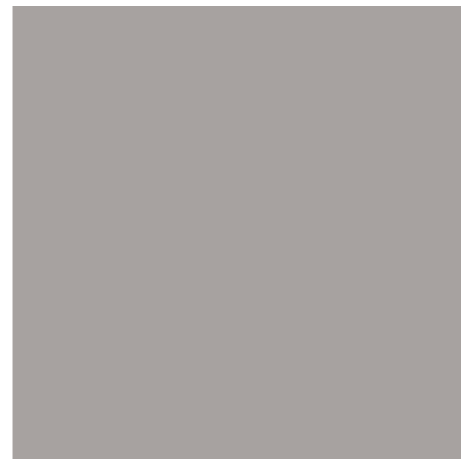

RAL 7036
Grigio platino / Platinum Grey

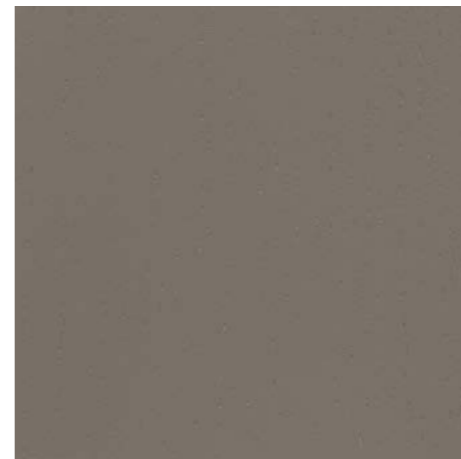

RAL 7039
Grigio quarzo / Quartz Grey



RAL 7040
Grigio finestra / Window Grey



RAL 7001
Grigio argento / Silver Grey

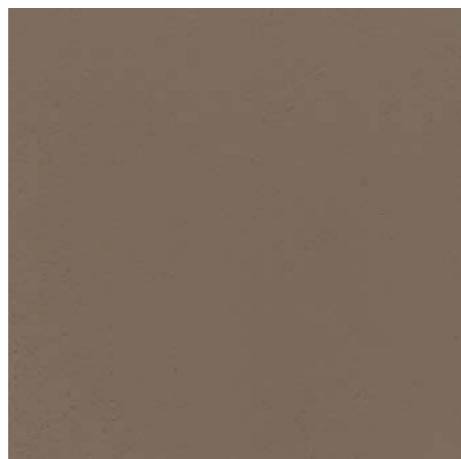

RAL 7006
Grigio beige / Beige Grey

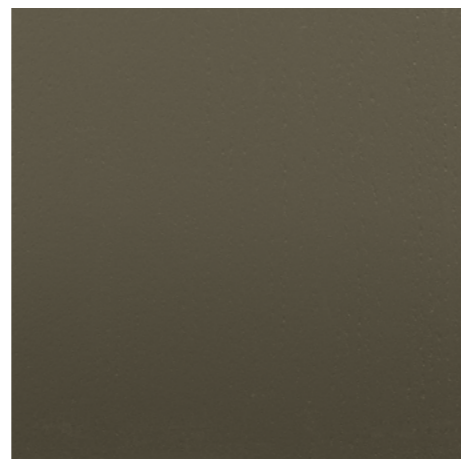

RAL 7013
Grigio brunastro / Brownish grey



RAL 7044
Grigio seta / Silk Grey

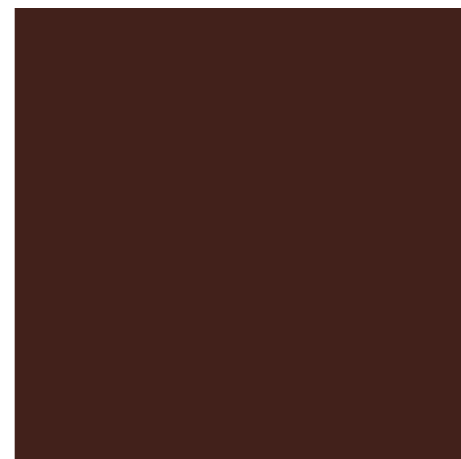

RAL 8017
Marrone cioccolato / Chocolate Brown



RAL 8019
Marrone grigiastro / Grey Brown

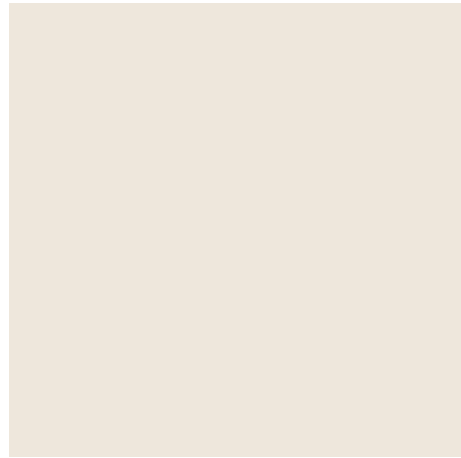

RAL 9001
Bianco Crema / Cream White

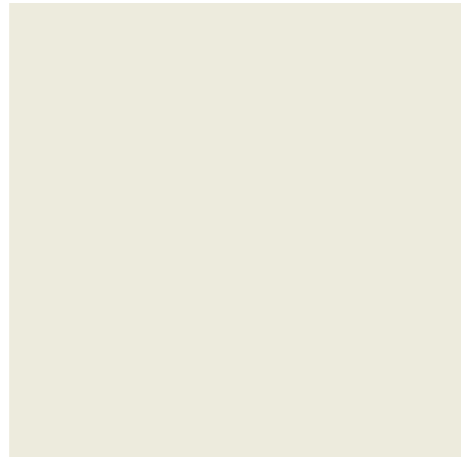

RAL 9002
Bianco grigiastro / Grey White

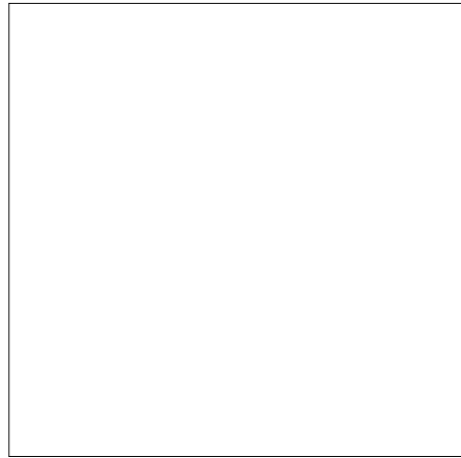

RAL 9003
Bianco segnale / Signal White



RAL 9005
Nero intenso / Jet Black



RAL 9006
Alluminio brillante / White Aluminium



RAL 9010
Bianco puro / Pure White

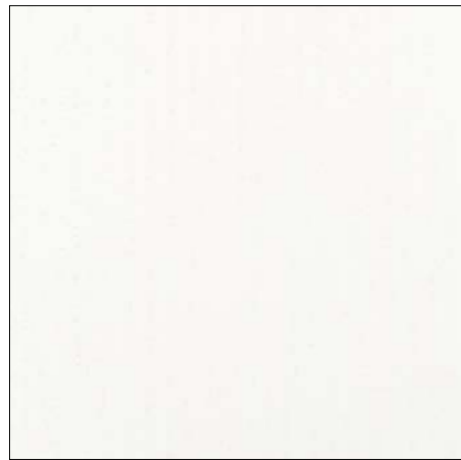

RAL 9016
Bianco traffico / Traffic White

DISPONIBILI NELLE FINITURE LACCATE NCS / NCS LACQUERS

Adatto per esterni // Suitable for outdoors



S2502-R



S4502-R

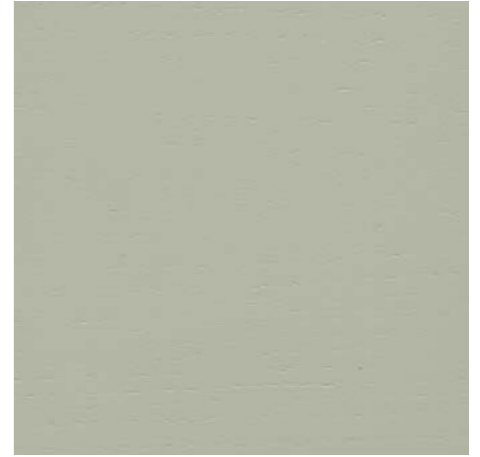

S3005-G50Y

DISPONIBILI NELLE FINITURE LACCATE METAL SKIN / AVAILABLE IN METAL SKIN LACQUERED FINISHING

Su base HDF solo per ambienti interni su entrambi i lati della porta // On HDF base just for indoors on both sides of the door
Su base Okoumé adatto per ambienti esterni su entrambi i lati della // On Okoumé base just for outdoors on both sides of the door

EFFETTO PELTRO / PEWTER EFFECT



Acciaio / Steel

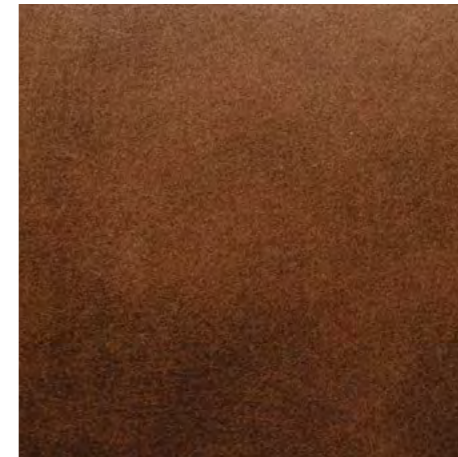

Bronzo / Bronze



Ferro / Iron



Oro Rosa / Pink Gold



Ottone / Brass



Tricolor / Tricolor

Trattasi di verniciatura manuale disomogenea che rappresenta una caratteristica di unicità artigianale del prodotto.
This is a manual painting that represents a characteristic of the craft uniqueness of the product

EFFETTO PATINATO / PATINATE EFFECT

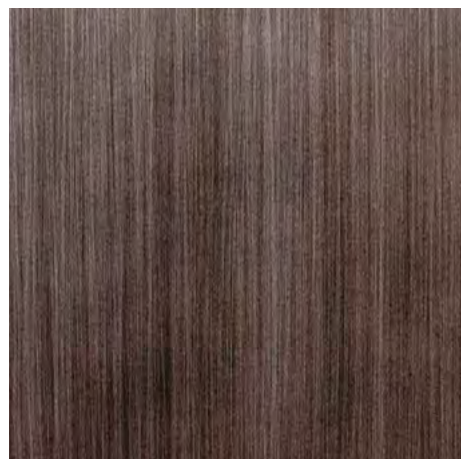

Acciaio / Steel

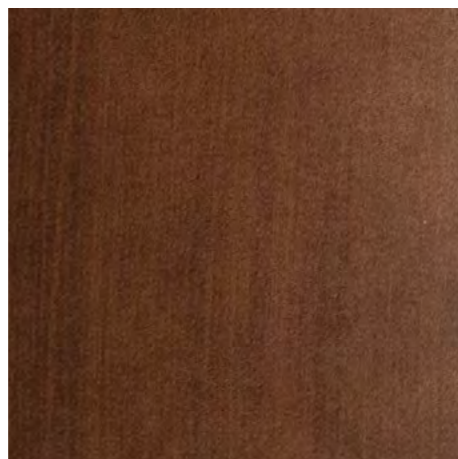

Bronzo / Bronze



Ferro / Iron

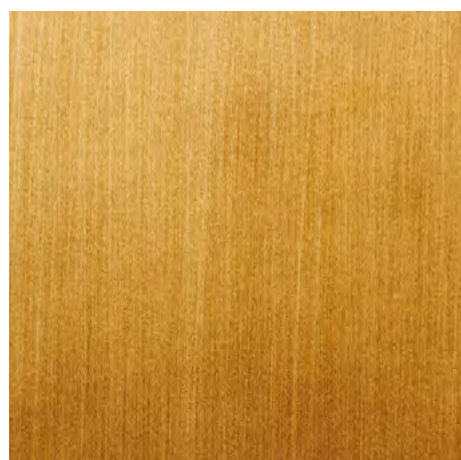

Ottone / Brass



Oro Rosa / Pink Gold

Trattasi di verniciatura manuale disomogenea che rappresenta una caratteristica di unicità artigianale del prodotto.
This is a manual painting that represents a characteristic of the craft uniqueness of the product

HDF

Solo per ambienti interni su entrambi i lati / For interiors only, on both door sides



Tutti i colori RAL
All RAL colors

ALTRE ESSENZE

PANNELLO IN MULTISTRATO CON SUPERFICIE IN ESSENZA / HARDWOOD PLYWOOD
PANNELLO IN MULTISTRATO MARINO TASSELLATO E NOBILITATO IN ESSENZA
WOOD VENEER MARINE PLYWOOD WITH TIMBER INSERTS

NATURALI / NATURALS

Adatto per esterni solo su lato esterno porta // Suitable for outdoors

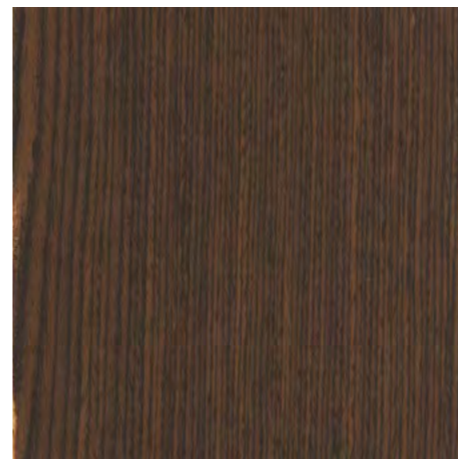

Wengè / Wengè

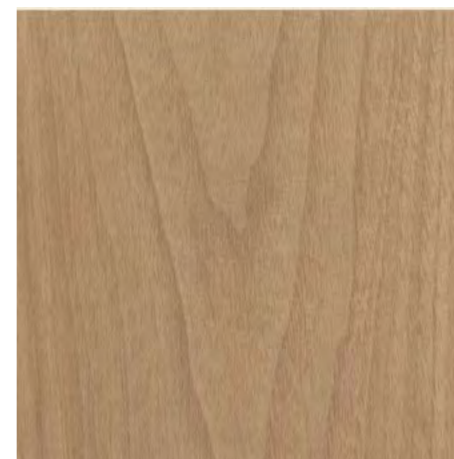

Noce Canaletto / Canaletto Walnut



Noce Nazionale medio / Walnut medium

Adatto per esterni solo su lato esterno porta // Suitable for outdoors

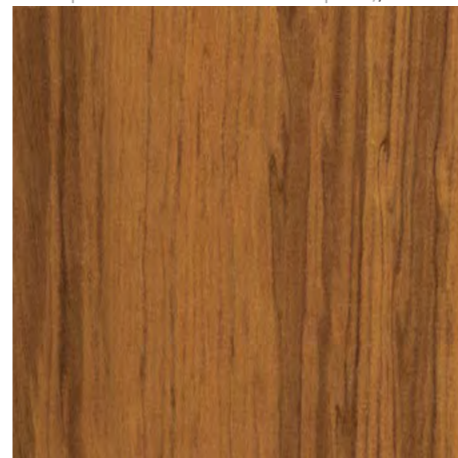

Teak / Teak

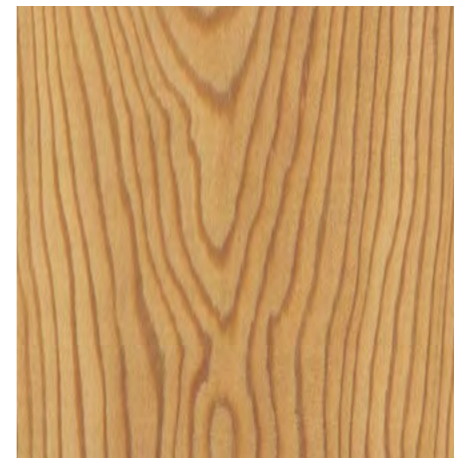

Larice cotto / Aged Larch



Abete nordico / Northern Spruce

MATERIA LAMINAM / MATERIA LAMINAM

Solo per ambienti interni su lato esterno porta / For interiors only, door external side

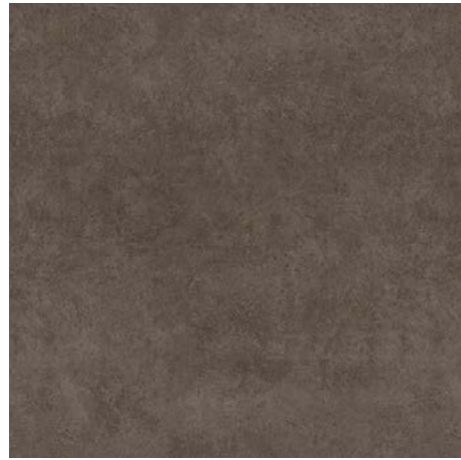

Fokus Piombo / Fokus lead



Emperador Extra / Emperador Extra



Ossido Bruno / Brown Oxide



Ossido Verderame / Verdigris Oxide



Nero Assoluto / Pure black

MATERIA ARENARIA / MATERIA ARENARIA

Su base HDF solo per ambienti interni su entrambi i lati della porta // On HDF base just for indoors on both sides of the door
Su base Okoumé adatto per ambienti esterni su entrambi i lati della porta // On Okoumé base just for outdoors on both sides of the door

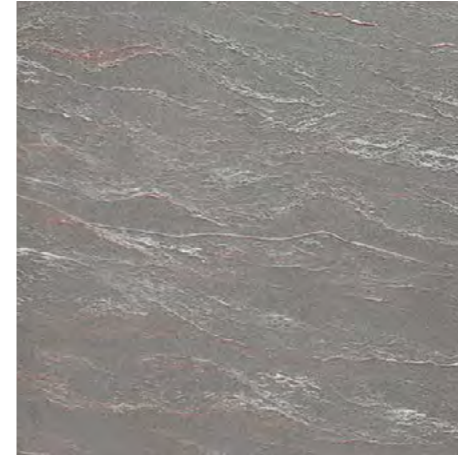

Grecia



Belgio



Sudafrica

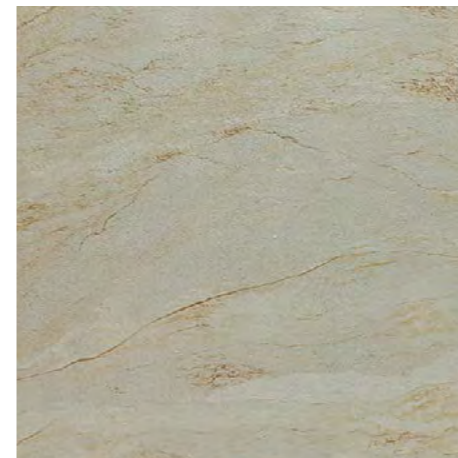

India

ALLUMINIO / ALUMINUM

Su base MDF adatto per interni - su base poliuretano adatto per esterni, entrambi su lato esterno porta
Suitable for interiors on MDF base - suitable for exteriors on polyurethane base, both on door external side

OPACHI / MATT



1013 Bianco Perla Pearl White	3005 Rosso Vino Wine Red	5010 Blue Genziana Gentian Blue	6005 Verde Grinzato Moss Green	7035 Grigio Chiaro Light Grey	8017 Marrone Cioccolato Chocolate Brown	8017 Marrone Grinzato Moss Brown	9010 Bianco Puro Pure White
-------------------------------------	--------------------------------	---------------------------------------	--------------------------------------	-------------------------------------	---	--	-----------------------------------



9006 Bianco Alluminio Aluminum White	1002 Giallo Sabbia Sand Yellow	1021 Giallo di Cadmio Cadmio Yellow	1019 Beige Scuro Dark Beige	3020 Rosso Traffico Traffic Red	5003 Blu Zaffiro Sapphire Blue	6029 Verde Menta Mint Green	6021 Verde Pallido Opaque Green
--	--------------------------------------	---	-----------------------------------	---------------------------------------	--------------------------------------	-----------------------------------	---------------------------------------



6005 Verde Moss Green	7036 Grigio Platino Platin Grey	7001 Grigio Argento Silver Grey	8019 Marrone Brown	9005 Nero Porfido Porphyry Black	9016 Bianco Traffico Traffic White
-----------------------------	---------------------------------------	---------------------------------------	--------------------------	--	--

DECORATI LEGNO / DECORATED WOOD

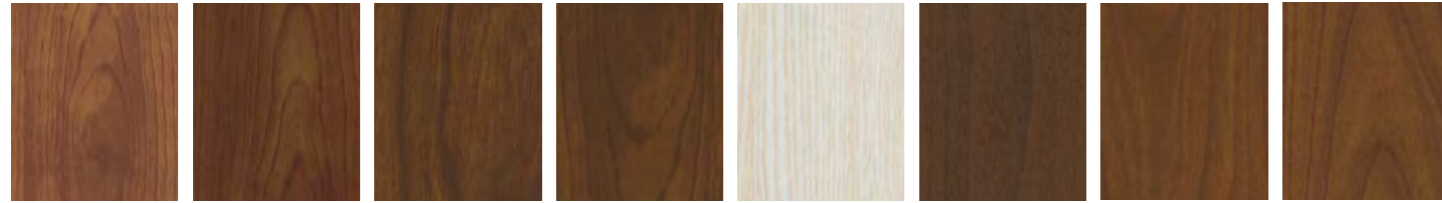

Castano Chiaro Ruvido Rough light brown	Castano Scuro Ruvido Rough dark brown	Noce Walnut	Castagno Chestnut	Bianco Venato Veneered White	Noce Scuro Dark Walnut	Ciliegio Scuro Dark Cherry	Ciliegio Ruvido Rough Cherry
---	--	----------------	----------------------	---------------------------------	---------------------------	-------------------------------	---------------------------------



Ciliegio Chiaro Light Cherry	Noce Chiaro Light Walnut	Renolit Chiaro Light Renolit	Pino Pine tree	Ciliegio Tinto Gold Gold colored Cherry	Rovere Sbiancato Whitenened Oak
---------------------------------	-----------------------------	---------------------------------	-------------------	--	------------------------------------

MANIGLIERIA BASE / STANDARD HANDLES

MANIGLIA LUCE / HANDLE LUCE



Cromo satinato
Satin chrome



Bronzo satinato
Satin bronze



Antracite
Anthracite

MANIGLIA LUCE 2 / HANDLE LUCE 2



Cromo satinato
Satin chrome



Bronzo satinato
Satin bronze



Antracite
Anthracite

MANIGLIERIA SUPERIOR / SUPERIOR HANDLES

MANIGLIA CHOP / HANDLE CHOP



Cromo satinato
Satin chrome



Bronzo satinato
Satin bronze



Antracite
Anthracite

MANIGLIA IKI / HANDLE IKI



Cromo satinato
Satin chrome



Antracite
Anthracite

MANIGLIA PROJECT / HANDLE PROJECT



Ottone Lucido
Polished Brass

MANIGLIERIA TOP/ TOP HANDLES

MANIGLIA BOOLE / HANDLE BOOLE



Cromo satinato
Satin chrome



Bronzo satinato
Satin bronze



Antracite
Anthracite

MANIGLIA INFINITO / HANDLE INFINITO



Cromo satinato
Satin chrome



Bronzo satinato
Satin bronze



Antracite
Anthracite

MANIGLIA DUE / HANDLE DUE



Cromo satinato
Satin chrome



Bronzo satinato
Satin bronze



Antracite
Anthracite

POMOLO GIREVOLE / SWIVEL KNOB

POMOLO PROJECT ZANCATA 02 / KNOB PROJECT ZANCATA 02



Cromo satinato
Satin chrome



Bronzo satinato
Satin bronze



Antracite
Anthracite

POMOLO OVUM / KNOB OVUM

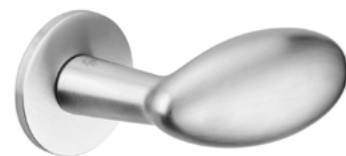

Cromo satinato
Satin chrome



Bronzo satinato
Satin bronze

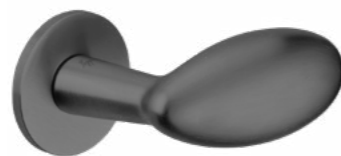

Antracite
Anthracite



Ottone Lucido
Polished Brass

POMOLO FISSO / FIXED KNOB

POMOLO EASY KNOB EASY



Cromo satinato
Satin chrome

Disponibile anche nella finitura
Bronzo satinato, Antracite o Ottone lucido
Also available in
Satin Bronze, Anthracite finish or Polished Brass

POMOLO QUADRO KNOB QUADRO



Cromo satinato
Satin chrome

Disponibile anche nella finitura
Bronzo satinato o Antracite
Also available in
Satin Bronze or Anthracite finish

MANIGLIONI / PULL BARS



KD
Acciaio inox
Stainless steel



QUADRO
Acciaio inox
Stainless steel

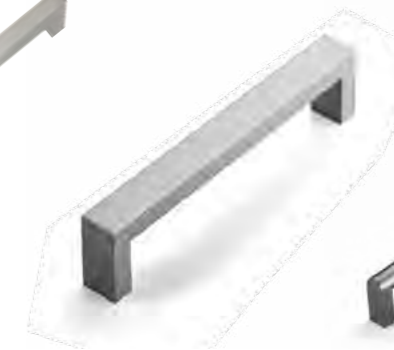

CORNER
Grigio, Bronzo, Silver
Grey, Bronze, Silver



LOPP
Grigio, Bronzo, Silver
Grey, Bronze, Silver

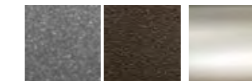

Disponibili a richiesta
altre soluzioni di maniglia
Other handle solutions
available on request

CARATTERISTICHE TECNICHE TECHNICAL CHARACTERISTICS

CHIUSURE DI SICUREZZA

- N° 1 deviatore doppio laterale superiore
- N° 1 deviatore doppio laterale inferiore
- N° 6 rostri fissi

CARATTERISTICHE TECNICHE

- SCOCCA in doppia lamiera elettrozincata spessore 12/10 con due rinforzi ad omega verticali spessore 12/10, tutto interamente puntato e saldato. Viene inserita una piastra di protezione serratura 30/10 in lamiera antitrapano, coibentata con lana di roccia.
- TELAIO da 20/10 di spessore, pressopiegato e verniciato a polveri termoidurenti nella tinta simil Ral 7016 (grigio antracite).
- CERNIERE a scomparsa design by Silvelox, regolabili su 3 assi, apertura massima 130°. Supportano il 30% di peso in più rispetto alle cerniere in commercio e per questo le porte mod. Perseo non necessitano della terza cerniera (in condizioni standard).
- DIMENSIONI MASSIME
1080 mm X 2690 mm (1 anta)
1980 mm X 2690 mm (2 ante)
- PESO anta + telaio = 90 Kg ca.

DOTAZIONI DI SERIE

- Carenatura fermapannello esterno in acciaio inox AISI 304 satinato
- Bordatura pannello interno da 10 mm di spessore
- Soglia mobile con lama para aria a ghigliottina autolivellante per chiusura a pavimento
- Defender antitubo con trattamento PVD
- Registro scrocco cromato regolabile montato sul telaio
- Kit cappucci copriceriera
- Guarnizione ad alte prestazioni sul telaio
- Guarnizione in silicone ad alte prestazioni sull'anta
- Serratura a cilindro europeo.
- Cilindro chiave/codolo, 5 chiavi padronali, 1 chiavi cantiere, Card di sicurezza (con numero seriale del cilindro)
- Sistema paraspifferi NO-AIR
- Sacchetto accessori con tutto il necessario per il montaggio

MULTIPOINT SECURITY LOCKS

- N° 1 Upper double deadbolt on the side
- N° 1 Lower double deadbolt on the side
- N° 6 Fixed Bolts

TECHNICAL CHARACTERISTICS

- CHASSIS Electrogalvanized 12/10 thick double metal sheet with 2 vertical 12/10 thick reinforcing point-by-point welded omegas. 30/10 thick insulated, anti-drill protection metal plate.
- FRAME 20/10 thick metal, thermosetting bent powder coated RAL7016 (anthracite gray) (fig. PE002).
- HINGES hidden hinges design by Silvelox, adjustable on 3 axes, maximum opening 130°. They support 30% more weight than the common hinges, for this reason the door Perseo doesn't need the third hinge (in standard conditions).
- MAXIMUM DIMENSIONS
1080 mm X 2690 mm (1 leaf)
1980 mm X 2690 mm (2 leaves)
- MAXIMUM WEIGHT chassis + frame = 90 Kg app.

STANDARD SETTINGS

- AISI 304 satin stainless steel perimetric carter (panel holder)
- Internal panel edging 10 mm thick (fig. PE003)
- Pavement sealing automatic draught excluder (fig. PE001)
- PVD treated external cylinder defender
- Frame mounted latch register
- Upvc hinges cover caps
- Frame mounted high performing perimetric weatherseal
- Door mounted high performing silicon weatherseal
- Lock with European cylinder
- CH/VOL cylinder, 5 main keys, 1 construction site keys, security card (with cylinder serial number)
- NO-AIR kit
- Assembly kit

TELAIO E CONTROLAIO / FRAME AND COUNTERFRAME

STANDARD
STANDARD

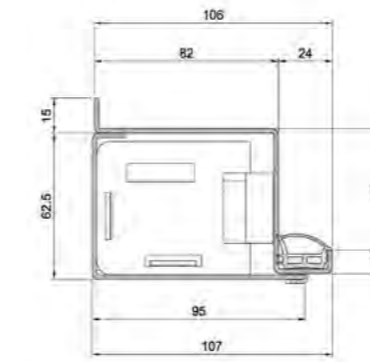

BATTUTA CONTRO SOGLIA / TIPO A
LOWER THRESHOLD JAMB / TYPE A

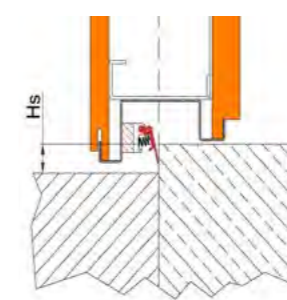

BATTUTA CONTRO SOGLIA / TIPO B
LOWER THRESHOLD JAMB / TYPE B

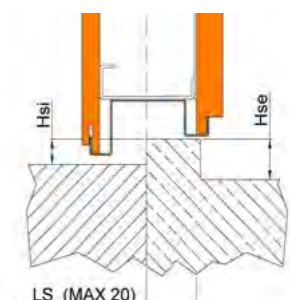

INSTALLAZIONE IN LUCE (TELAIO STANDARD) / WALL BETWEEN INSTALLATION (STANDARD FRAME)

- Misura da rilevare: Foro muro esterno (Dfe)
Battuta interna dx e sx min 100 mm
L Ln (luce netta in larghezza) = L Dfe (larghezza foro muro esterno) - 18 mm
H Ln (luce netta in altezza) = H Dfe (altezza foro muro esterno) - 9 mm

- Necessary measures: External wall opening (Dfe)
Internal jamb RH and LH min 100 mm
L Ln (net passage W) = L Dfe (external wall opening W) - 18 mm
H Ln (net passage H) = H Dfe (external wall opening H) - 9 mm

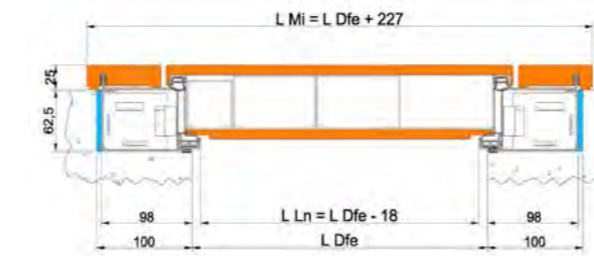

SEZIONE ORIZZONTALE
HORIZONTAL SECTION

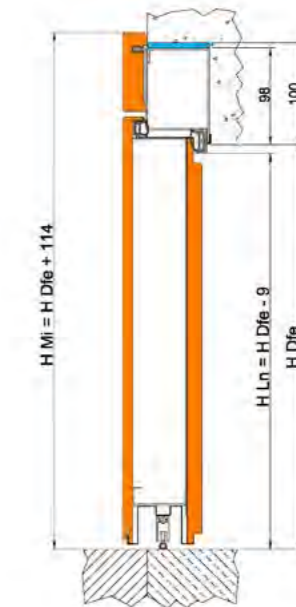

SEZIONE VERTICALE
VERTICAL SECTION

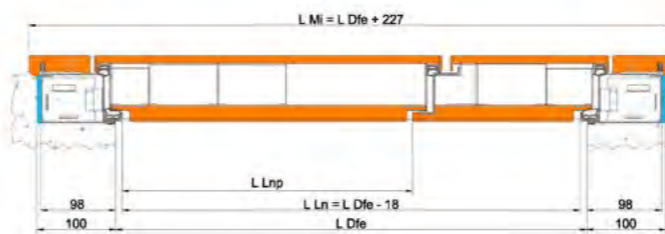

SEZIONE ORIZZONTALE - 2 ANTE
HORIZONTAL SECTION - 2 LEAVES

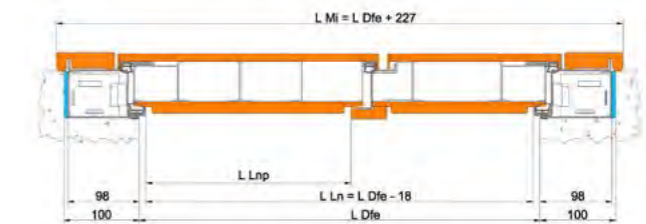

OBBLIGATORIO CON ESTETICA PANNELLO ESTERNO FAMILY BUGNE E MONOFRESATA
MANDATORY WITH EXTERNAL PANEL AESTHETIC FAMILY EMBOSSED AND MONOMILLED

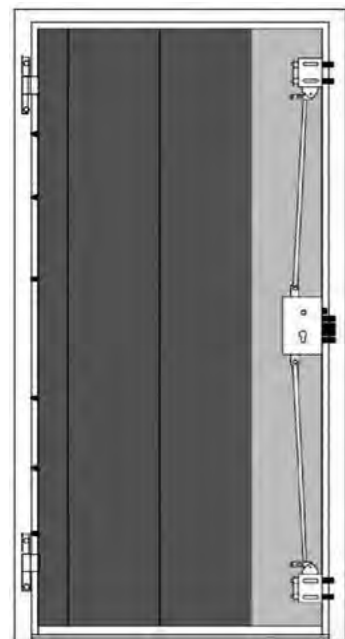

PRESTAZIONI	Performance	1ANTA
Acustica	Acoustics	40 dB
Termica	Thermal	1,2 W/m²K
Aria	Air	2
Acqua	Water	2
Vento	Wind	3
Antieffrazione	Anti-burglary	4

LATERALE FISSO CIECO IN PANNELLO (STESSA FINITURA DELL'ANTA) / FIXED LATERAL PANEL (SAME FINISHING AS THE DOOR)

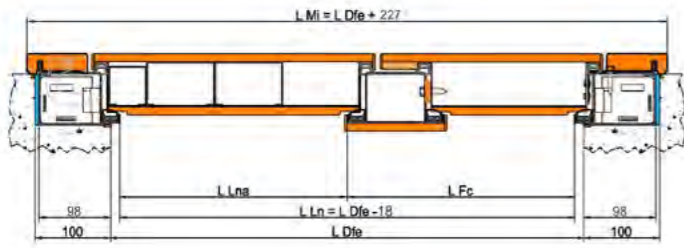

OLTRE LUCE
WALL BEHIND

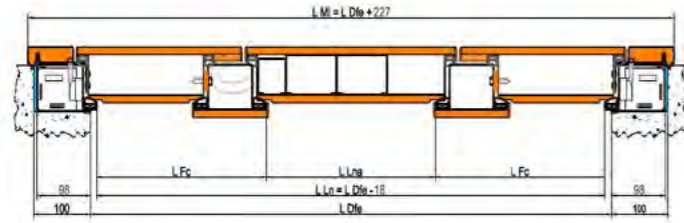

DOPPIO OLTRE LUCE
DOUBLE-WALL BEHIND

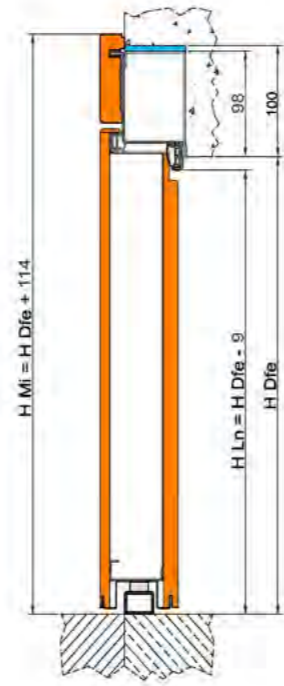

OLTRE LUCE
WALL BEHIND

SOPRALZO FISSO CIECO IN PANNELLO (STESSA FINITURA DELL'ANTA) / FIXED TRANSOM (SAME FINISHING AS THE DOOR)

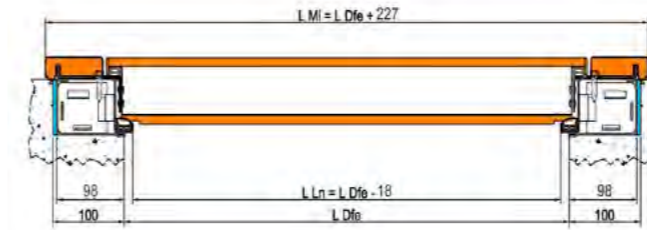

OLTRE LUCE
WALL BEHIND

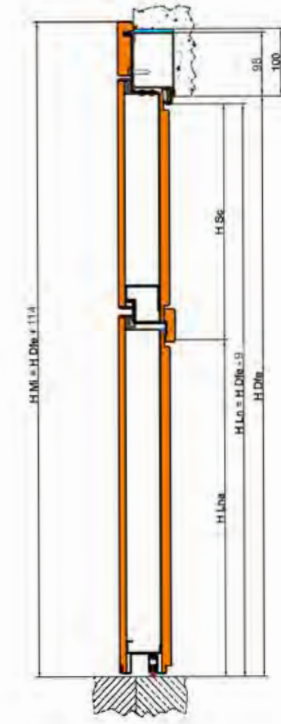

OLTRE LUCE
WALL BEHIND

LATERALE FISSO PREDISPOSTO PER VETRO / FIXED LATERAL PREPARED FOR GLASS

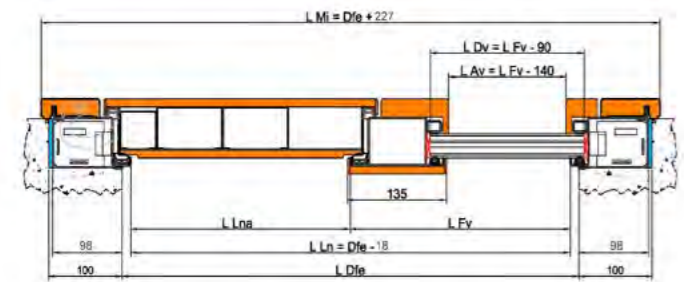

OLTRE LUCE
WALL BEHIND

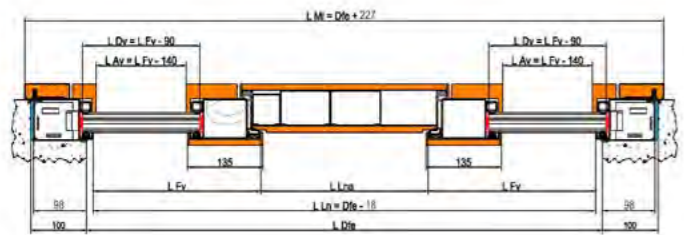

DOPPIO OLTRE LUCE
DOUBLE-WALL BEHIND

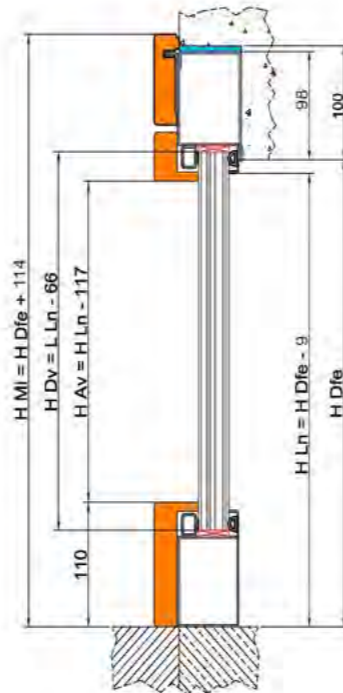

OLTRE LUCE
WALL BEHIND

SOPRALZO FISSO PREDISPOSTO PER VETRO / FIXED TRANSOM PREPARED FOR GLASS

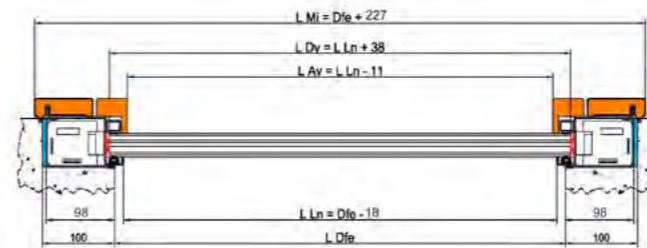

OLTRE LUCE
WALL BEHIND

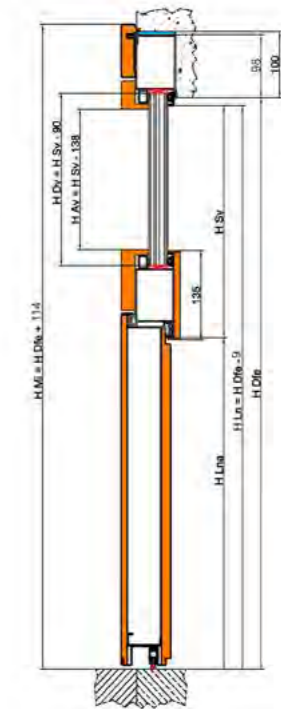

OLTRE LUCE
WALL BEHIND

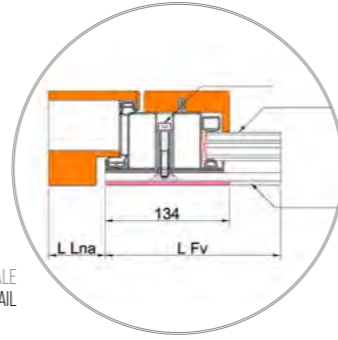

DETTAGLIO LATERALE
LATERAL PANEL DETAIL

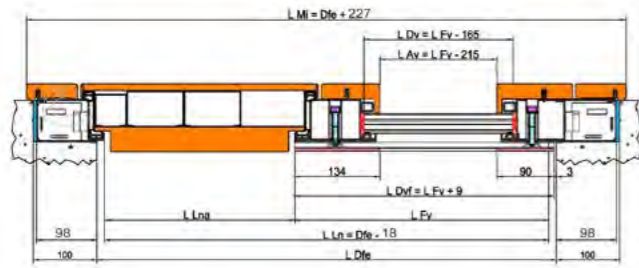

LATERALE
LATERAL

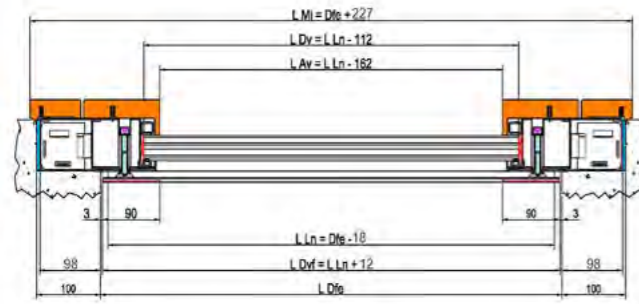

SOPRALZO
TRANSOM

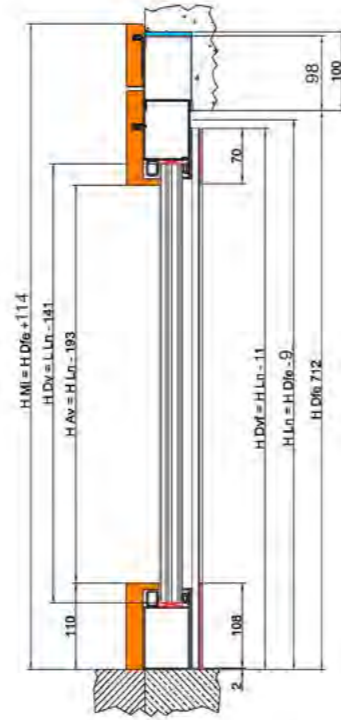

LATERALE
LATERAL

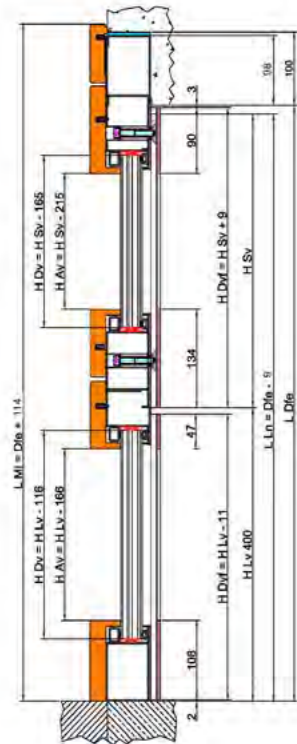

LATERALE SOPRALZO
LATERAL TRANSOM

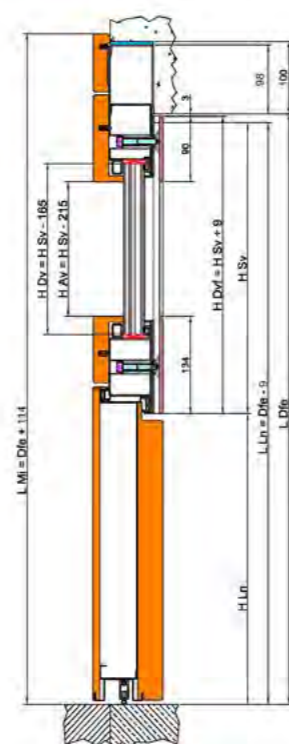

SOPRALZO
TRANSOM



I nostri cataloghi sono stampati
su carta ecologica certificata FSC

Our catalogs are printed
on FSC certified ecological paper



Cod. D00047 Rev 3



SILVELOX
GROUP SPA

SILVELOX GROUP SPA

Headquarters and Production plant:

Viale Venezia, 37 I-38050 Castelnuovo - Trento - Italy
Tel. (+39) 0461 755 755 - Fax (+39) 0461 752 466
info@silvelox.it - silvelox@cgn.legalmail.it - www.silvelox.it

Production plant:

Via Rossi, 14 I-25010 Remedello - Brescia - Italy
Tel. (+39) 030 258 5500 - Fax (+39) 030 258 2537
seip@silvelox.it - www.seipdoors.it

